





|                                                                                                                                                                                                                                                                                                                                                            |                                                                                            |                               |                |                                                                                                                                                                                                                                                                                                          |
|------------------------------------------------------------------------------------------------------------------------------------------------------------------------------------------------------------------------------------------------------------------------------------------------------------------------------------------------------------|--------------------------------------------------------------------------------------------|-------------------------------|----------------|----------------------------------------------------------------------------------------------------------------------------------------------------------------------------------------------------------------------------------------------------------------------------------------------------------|
| UNLESS OTHERWISE SPECIFIED<br><br>DIMENSIONAL TOLERANCES:<br><6 = ± 0.05<br>6-30 = ± 0.1<br>30-120 = ± 0.15<br>>120 = ± 0.2<br>ANGLES = ± 0.5 °<br><br>PROPRIETARY NOTICE:<br><br>ALL INFORMATION HEREIN IS THE SOLE AND EXCLUSIVE PROPERTY OF GLP, AND MAY NOT BE USED, DISCLOSED OR REPRODUCED IN ANY MANNER WITHOUT THE ADVANCE WRITTEN CONSENT OF GLP. | DRW:                                                                                       | PART NO.: PART_NO             |                |  GERMAN LIGHT PRODUCTS GMBH<br>IM STOECKMAEDLE 13<br>76307 KARLSBAD - GERMANY<br><br> PHONE: +49 (0)7248/92719-0<br>WWW.GLP.DE |
|                                                                                                                                                                                                                                                                                                                                                            | CHK:                                                                                       | DRAWING NO.: DRAWING_NO       |                |                                                                                                                                                                                                                                                                                                          |
|                                                                                                                                                                                                                                                                                                                                                            | APR:                                                                                       | DATE: 28.06.12                | REV.: REVISION |                                                                                                                                                                                                                                                                                                          |
|                                                                                                                                                                                                                                                                                                                                                            | SIZE<br><b>A4</b><br><br>THIRD ANGLE PROJ.                                                 | DESCRIPTION:<br>X4 Dimensions |                |                                                                                                                                                                                                                                                                                                          |
|                                                                                                                                                                                                                                                                                                                                                            | MATERIAL: MATERIAL                                                                         |                               | FINISH:        |                                                                                                                                                                                                                                                                                                          |
|                                                                                                                                                                                                                                                                                                                                                            | ALL DIMENSIONS ARE IN MILLIMETERS UNLESS NOTED OTHERWISE. REMOVE ALL BURRS AN SHARP EDGES. |                               |                | FILENAME:<br>X4_DIMENSIONS                                                                                                                                                                                                                                                                               |
|                                                                                                                                                                                                                                                                                                                                                            | DO NOT SCALE                                                                               |                               | SCALE 1:5      |                                                                                                                                                                                                                                                                                                          |
|                                                                                                                                                                                                                                                                                                                                                            |                                                                                            |                               |                | SHEET 1 OF 2                                                                                                                                                                                                                                                                                             |

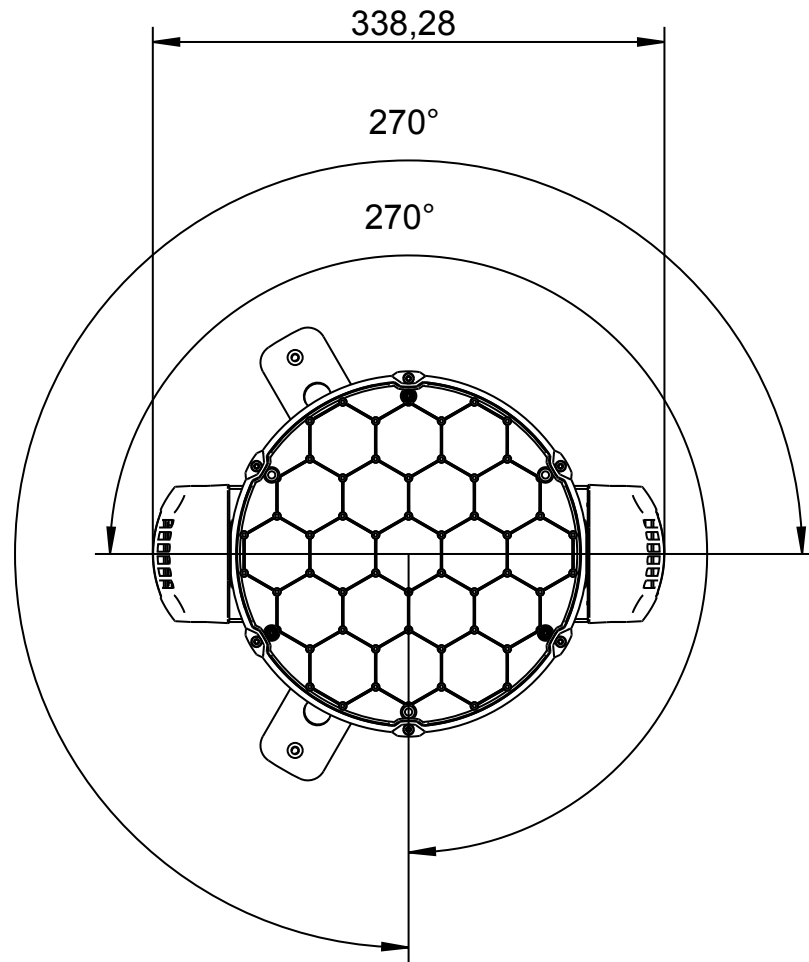

Pan movement range: 540°

|                                                                                                                                                                                                                                                                                                                                                           |                                                                                            |                               |           |                                                                                                                                                                                                                                                                                                          |
|-----------------------------------------------------------------------------------------------------------------------------------------------------------------------------------------------------------------------------------------------------------------------------------------------------------------------------------------------------------|--------------------------------------------------------------------------------------------|-------------------------------|-----------|----------------------------------------------------------------------------------------------------------------------------------------------------------------------------------------------------------------------------------------------------------------------------------------------------------|
| UNLESS OTHERWISE SPECIFIED<br><br>DIMENSIONAL TOLERANCES:<br><6 = ± 0.05<br>6-30 = ± 0.1<br>30-120 = ± 0.15<br>>120 = ± 0.2<br>ANGLES = ± 0.5°<br><br>PROPRIETARY NOTICE:<br><br>ALL INFORMATION HEREIN IS THE SOLE AND EXCLUSIVE PROPERTY OF GLP, AND MAY NOT BE USED, DISCLOSED OR REPRODUCED IN ANY MANNER WITHOUT THE ADVANCE WRITTEN CONSENT OF GLP. | DRW:                                                                                       | PART NO.:                     |           |  GERMAN LIGHT PRODUCTS GMBH<br>IM STOECKMAEDLE 13<br>76307 KARLSBAD - GERMANY<br><br> PHONE: +49 (0)7248/92719-0<br>WWW.GLP.DE |
|                                                                                                                                                                                                                                                                                                                                                           | CHK:                                                                                       | DRAWING NO.:                  |           |                                                                                                                                                                                                                                                                                                          |
|                                                                                                                                                                                                                                                                                                                                                           | APR:                                                                                       | DATE: 29.06.12                | REV.:     |                                                                                                                                                                                                                                                                                                          |
|                                                                                                                                                                                                                                                                                                                                                           | SIZE<br><b>A4</b><br><br>THIRD ANGLE PROJ.                                                 | DESCRIPTION:<br>X4 Dimensions |           |                                                                                                                                                                                                                                                                                                          |
|                                                                                                                                                                                                                                                                                                                                                           | MATERIAL:                                                                                  |                               | FINISH:   |                                                                                                                                                                                                                                                                                                          |
|                                                                                                                                                                                                                                                                                                                                                           | ALL DIMENSIONS ARE IN MILLIMETERS UNLESS NOTED OTHERWISE. REMOVE ALL BURRS AN SHARP EDGES. |                               |           | FILENAME:<br>X4_DIMENSIONS                                                                                                                                                                                                                                                                               |
|                                                                                                                                                                                                                                                                                                                                                           | DO NOT SCALE                                                                               |                               | SCALE 1:5 |                                                                                                                                                                                                                                                                                                          |
|                                                                                                                                                                                                                                                                                                                                                           |                                                                                            |                               |           | SHEET 2 OF 2                                                                                                                                                                                                                                                                                             |