

**FUSION**  
by GLP

# Fusion Stick FS16Z

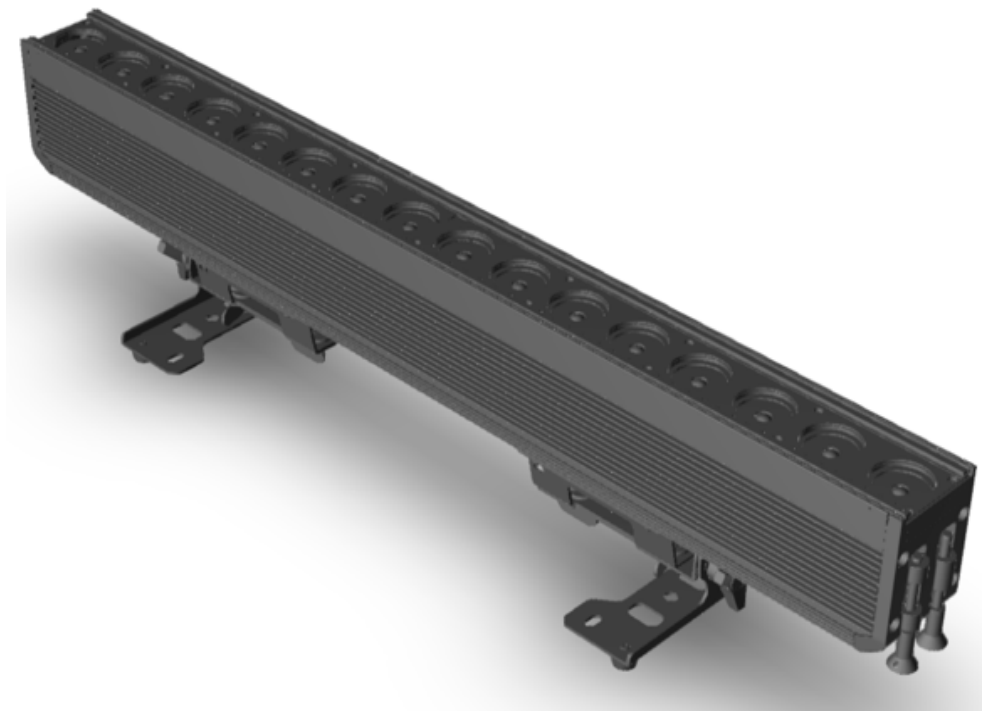

## User Manual

Software version 1.0.0.0



GLP® Fusion Stick FS16Z User Manual – Revision A

This document covers fixture software version 1.0.0.0

---

© 2018-2021 German Light Products GmbH. All rights reserved.

The marks 'GLP' and 'German Light Products' are trademarks registered as the property of German Light Products GmbH in Germany, in the United States of America and in other countries.

The information contained in this document is subject to change without notice. German Light Products GmbH and all affiliated companies disclaim liability for any injury, damage, direct or indirect loss, consequential or economic loss or any other loss occasioned by the use of, inability to use or reliance on the information contained in this document.

Manufacturer's head office:

German Light Products GmbH (GLP), Industriestrasse 2, 76307 Karlsbad, Germany  
Tel (Germany): +49 7248 92719 - 0

Service & Support EMEA:

GLP, Industriestrasse 2, 76307 Karlsbad, Germany  
Tel. (Germany): +49 7248 9271955  
Email: [support@glp.de](mailto:support@glp.de)  
[www.glp.de](http://www.glp.de)

Service & Support USA:

GLP USA, 1145 Arroyo St., Ste. A, 91340 San Fernando, California  
Tel (USA): +1 818 767 8899  
Support (US): [info@germanlightproducts.com](mailto:info@germanlightproducts.com)  
[www.germanlightproducts.com](http://www.germanlightproducts.com)

## Table of Contents

1. Safety .....	5
Key to symbols .....	5
Electrical safety .....	6
Fire safety and protection from burns .....	7
Eye safety .....	8
Strobe safety .....	8
Installation safety and protection from personal injury .....	9
2. Avoiding damage to the fixture .....	11
General precautions .....	11
Avoiding damage from light sources and heat .....	11
IP rating .....	12
Avoiding damage from water and humidity .....	12
Avoiding damage from dust and airborne particles .....	13
Transportation and storage .....	13
GLP Service and Support .....	13
3. FS16Z overview .....	15
4. Installation .....	17
Permitted Mounting options .....	17
Securing fixtures with a safety cable .....	18
Attaching mounting brackets to the fixture .....	18
Using FS16Z Locking Pins .....	19
Standing horizontally on a surface .....	20
Installing on a rigging truss or similar structure .....	21
Side-to-side attachment .....	22
Vertical suspension from a rigging structure .....	23
Vertical installation standing on a surface .....	26
5. AC mains power .....	29
Included items .....	29
Connecting to power .....	29
Installing power connectors .....	30
Connecting multiple fixtures to power in a chain .....	30
6. Connecting to DMX data .....	31
7. Features .....	32
Zoom .....	32
Color wheel effect .....	32
RGBW color mixing .....	32
Shutter effect .....	32
Dimming .....	33
Patterns .....	33
Behavior when the fixture is not receiving a DMX signal .....	34

Display .....	34
Fixture information .....	35
Custom settings and factory defaults .....	35
8. IR Remote .....	36
9. Control menus and onboard display.....	37
10. Control menu layout.....	38
11. Service .....	43
Cleaning.....	43
Installing a glare shield .....	43
Installing a diffuser .....	44
GLP Service and Support.....	44
12. DMX control modes overview.....	45
13. DMX control channel layout .....	50
DMX Mode 1: Standard .....	51
DMX Mode 2: Advanced .....	53
DMX Mode 3: Pixel.....	56
DMX Mode 4: Compressed RGBW .....	58
DMX Mode 5: Compressed Pixel .....	59
Control / Settings channel.....	60
14. Guide to patterns.....	62
Static patterns .....	62
Static patterns(continued) .....	63
Animated patterns .....	64
15. Technical specifications.....	68
Optics.....	68
Effects .....	68
Control.....	68
Installation .....	68
Electrical.....	68
Connections .....	69
Construction .....	69
Thermal .....	69
Included items.....	69
Dimensions and weight.....	69
16. Dimensions .....	71
FS16Z with folding brackets .....	71
Folding brackets.....	71

## 1. Safety

### Key to symbols

The following symbols are used in the Fusion Stick FS16Z lighting fixture's user documentation:



**Warning!** Safety hazard.  
Risk of severe injury or death.



**Warning!** Hazardous voltage.  
Risk of lethal or severe electric shock.



**Warning!** See user manual for important safety information.



**Warning!** Fire hazard.



**Warning!** Risk of eye injury.

---



**Warning! Read the Fusion Stick FS16Z Quick Start and Safety Manual supplied with the fixture and available for download from [www.glp.de](http://www.glp.de) before installing, operating or servicing the fixture. The Quick Start and Safety Manual contains important information for the safe use of FS16Z fixtures. If you fail to read that information you may create a safety hazard with a risk of injury, death or damage.**

If you have any doubts or questions about how to use the GLP® Fusion Stick FS16Z lighting fixture safely, contact your GLP supplier for assistance. Your GLP supplier will be happy to help.

The user documentation for Fusion Stick FS16Z fixtures consists of three documents:

- The **FS16Z Quick Start and Safety Manual**, supplied with FS16Z fixtures and available for download from [www.glp.de](http://www.glp.de). The Quick Start and Safety Manual contains important safety information and installation instructions that the installer and user must read. It also contains dimensions drawings and technical specifications for the fixture.
- The **FS16Z User Manual**, available for download from [www.glp.de](http://www.glp.de). The User Manual explains features and control of FS16Z fixtures.
- The **FS16Z DMX Channel Index**, available for download from [www.glp.de](http://www.glp.de). The Channel Index is a separate document containing the DMX control channel layout and DMX commands available in the fixture. This information is also included in the User Manual.

The FS16Z is intended for use by experienced professionals with the knowledge and skills to set up, operate, and maintain high-powered, remotely controlled lighting

---

equipment safely and efficiently. These operations require expertise that may not be provided in this manual.

- Respect all warnings and directions given in the fixture's user documentation and on the fixture. Read the fixture's Quick Start and Safety Manual and familiarize yourself with the safety precautions it contains before installing, using or servicing the fixture. GLP and affiliated companies will take no responsibility for damage or injury resulting from disregard for the information in the user documentation.
- Check the GLP website at [www.glp.de](http://www.glp.de) and make sure that you have the latest versions of the fixture's Quick Start and Safety Manual and this user manual.
- Check the fixture software version indicated on page 2 of this user manual and then use the fixture's control panel to check the version installed in the fixture. If the versions are not the same, the user manual may still cover the fixture, because software updates do not always affect the use of the fixture. However, it is possible that this manual does not match the fixture perfectly. Software release notes can help clarify this question. You can consult software release notes and download the correct version of this user manual on the GLP website if necessary.
- Make both the Quick Start and Safety Manual and this user manual available to all persons who will install, operate or service the fixture. Save both documents for future reference.
- If you have any questions about the safe operation of the fixture, please contact an authorized GLP distributor (see list of distributors at [www.glp.de](http://www.glp.de)).



### **Electrical safety**

- Do not allow the fixture to become immersed. Do not expose the fixture to high-pressure water projections.
- Keep any unused connectors on the fixture sealed with their protective caps at all times, both when the fixture is in use and when not in use.
- Use only a source of AC mains power that complies with local building and electrical codes and has both overload and ground fault (earth fault) protection.
- Ensure that the fixture is electrically connected to ground (earth).
- Disconnect the fixture from AC mains power before carrying out any installation or maintenance work and when the fixture is not in use.
- Disconnect the fixture from power immediately if any seal, cover, cable, connector or other component is damaged, defective, deformed or showing signs of overheating. Do not reapply power until the fixture has been repaired and made safe by a technician authorized by GLP.
- Check that all power distribution equipment, cables and connectors are in perfect condition, rated for the electrical requirements of all connected devices, suitable for their application and suitable for the installation environment.

- Use only Neutrik PowerCON TRUE1 cable connectors for AC mains power input at the fixture's Mains IN connector and for relaying AC mains power from one fixture's Mains OUT (Thru) connector to another fixture's Mains IN connector.
  - Use minimum 14 AWG or 1.5 mm<sup>2</sup> power input and relay cables that are minimum 16 A-rated and temperature-rated to suit the application. In the USA and Canada the cables must be UL-listed, type SJT or equivalent. In the EU the cables must be type H05VV-F or equivalent.
  - Do not connect devices to power in a chain if the total maximum current draw of all the devices in the chain when added together will exceed the current rating of any cable or connector used at any point in the chain. The supplied power input cable is rated as follows:
    - US power cable: 16 A, 14 AWG, UL-listed, E304117, SJT, 4.9 ft.
    - EU power cable: 16 A, 1.5 mm<sup>2</sup>, H07RN-F, 1.5 m.
- Do not connect more than three (3) Fusion FS16Z fixtures to power in a chain at 100-120 V, 60 Hz.
- Do not connect more than six (6) Fusion FS16Z fixtures to power in a chain at 200-240 V, 50 Hz.
- The voltage and frequency at the Mains OUT socket are the same as the voltage and frequency applied to the Mains IN socket. Only connect devices to the Mains Out socket that accept this voltage and frequency.
  - Fusion FS16Z fixtures do not have a user-replaceable fuse. If you suspect that a fuse has blown, disconnect the fixture from power and send it to a technician authorized by GLP for repair.



### **Fire safety and protection from burns**

- Do not operate the fixture if the ambient temperature (Ta) exceeds 40° C / 104° F.
- The surface of the fixture's casing can reach up to 90° C / 194° F during operation. Avoid contact by persons and materials. Do not install the fixture in a location where there is a risk of accidental contact. Allow the fixture to cool for at least 20 minutes before handling
- Keep the fixture well away from flammable materials.
- Keep all combustible materials (e.g. fabric, wood, paper) at least 0.2 m / 8 in. away from the fixture.
- Ensure that there is free and unobstructed airflow around the fixture.
- Do not illuminate surfaces within 0.2 m / 8 in. of the fixture. The light output from the fixture is powerful enough to cause burns or fire in illuminated objects at very close range.

- Do not place any optical components other than Fusion FS16Z accessories from GLP onto the front of the fixture.
- Do not stick filters, masks or other materials onto the fixture. Do not block the light output in any way. The front surface becomes hot during operation and can melt or ignite objects that are in contact with the surface. Ensure that the front surface is clean and unobstructed at all times in order to prevent a fire hazard and damage to the fixture.
- The fixture's optical components can focus the sun's rays, creating a risk of fire and damage. Do not expose the front of the fixture to sunlight or any other intense light source, even from an angle.



### Eye safety

- The FS16Z is classified as a Risk Group 2 lighting fixture according to EN 62471. Possibly hazardous radiation emitted. Do not stare into the light output from the fixture. May be harmful to the eyes.
- Do not look at the fixture's light output with optical instruments or any device that may concentrate the light output.
- Make sure that persons near to or working on the fixture are not looking directly into the light output when the fixture lights up suddenly. This can happen when power is applied, when the fixture receives a DMX signal, or when certain control menu items are selected.
- The warning below is printed on the fixture. If the warning becomes impossible to read, replace it with a label reproduced from this illustration:

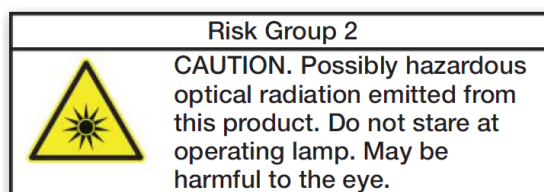

Provide well-lit conditions to reduce the pupil diameter of anyone working on or near the fixture.



### Strobe safety

- Flashing light, particularly at 5 - 30 Hz, may cause seizures in persons with photosensitive epilepsy. Do not use strobe effects for extended periods.



- Comply with local regulations on the use of strobe lighting and notify the public in advance with highly visible warning signs when strobe effects are used.
- If a seizure occurs, stop using strobe effects. Seek professional medical help. Note the time that the seizure starts and finishes. Call emergency medical help urgently if the seizure lasts more than five minutes, if it is the person's first seizure, or if the person is injured. While waiting for help to arrive, protect the affected person from injuring themselves on hard or sharp objects. If necessary, move the person to a safe place. Lay them on their side with their head supported to prevent it from hitting the floor. Loosen any tight clothing around their neck. Do not use force to hold the person or restrict their movements. Do not put anything in their mouth, including your fingers.



### **Installation safety and protection from personal injury**

- Installation must be performed by qualified personnel only and carried out in accordance with all locally applicable regulations such as DIN VDE 0711-217.
- The fixture is not portable when installed.
- Ensure that the supporting structure and installation hardware used can hold at least ten times the weight of the load that they support.
- Fasten the fixture to a structure or surface only as directed in this manual and only with hardware that is specifically designed and rated for its purpose. Do not use a safety cable as the primary means of support. Check that installation hardware is in perfect condition. Fasteners must be steel grade 8.8 strength or better. Rigging clamps must be half-coupler type that completely encircle the rigging truss chord.
- If the fixture is installed in a location where it may cause injury or damage if it falls, install as directed in this manual a safety cable or similar secondary attachment that will hold the fixture if a primary attachment fails. The secondary attachment must be approved by an official body such as TÜV as a safety attachment for the weight that it secures, it must comply with EN 60598-2-17 Section 17.6.6, and it must be able to support a static suspended load that is ten times the weight that it secures.
- If the fixture is installed in a location where it may be exposed to forces such as wind pressure, vibration or movement, make sure that the installation can withstand these forces. Monitor weather forecasts constantly. Take down the installation immediately if there is any risk of weather conditions that could destabilize the installation.
- Check that all covers and items of rigging hardware are secure before using the fixture. Do not operate the fixture with missing or damaged covers, shields or any optical component.
- Restrict access below the work area and work from a stable platform whenever installing, servicing or moving the fixture.
- If the fixture becomes damaged, stop using it immediately and disconnect it from power. Do not attempt to use a fixture that is obviously damaged.

- Do not modify the fixture in any way not described in its user documentation.
- Install genuine GLP parts only.

## 2. Avoiding damage to the fixture

**Important! Follow the directions in this section carefully, or the fixture may suffer damage that is not covered by the product warranty.**

### General precautions

Do not drop the fixture or expose it to mechanical stress.

Protect the onboard LCD display and control panel from shocks, or they may suffer damage that is not covered by the product warranty.

Do not expose the fixture to heat (from other lighting fixtures for example).

Clean optical components only as directed. Oils, solvents, and other chemicals commonly used for cleaning can damage the lens coatings and surfaces.

Use only original spare parts. Do not make any structural modifications to the fixture or you will void the product warranty.

### Avoiding damage from light sources and heat

Do not point the front of the fixture towards the sun or other strong light sources. Strong light can cause internal damage to the fixture, melting components or starting an internal fire within seconds.

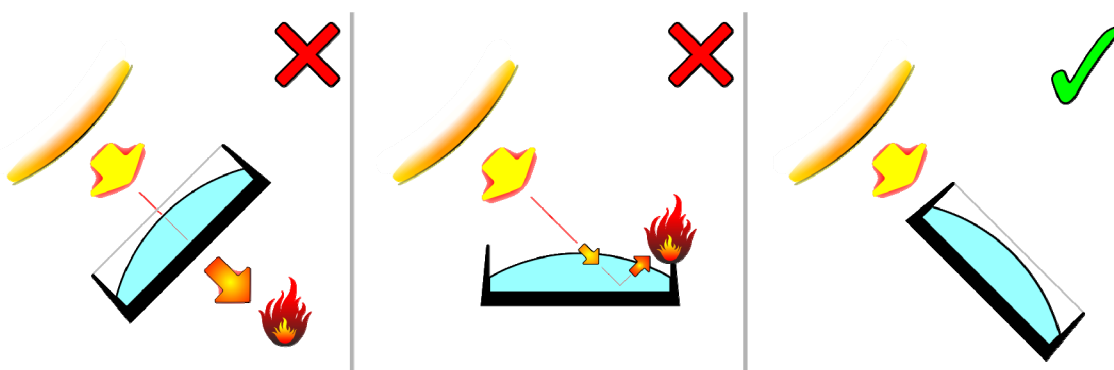

**Figure 1. Avoiding damage from light sources**

Damage can occur whether the fixture is powered on or off. See Figure 1. Damage can also occur if the light hits the front of the fixture at an angle: the fixture does not need to be pointing *directly* at the sun or other light source.

To avoid problems from strong light sources:

- Do not expose the front of the fixture to sunlight or any other strong light source.
- In outdoor applications during daylight, make sure that the front face of the fixture is shielded or points away from the sun, even when not in use.
- Do not aim other high-powered beam lights directly at the fixture.

Do not operate the fixture in ambient temperatures above 40° C / 104° F. Allow free airflow around the fixture.

## IP rating

FS16Z fixtures are IP65-rated:

- **IP** stands for Ingress (entry into the fixture) Protection.
- The first figure **6** in the rating means that fixtures are protected against the entry of dust and airborne particles.
- The second figure **5** in the rating means that fixtures are protected against the entry of rain and water projections from all angles. Fixtures are not protected against immersion in water and they are not protected against high-pressure water jets.

## Avoiding damage from water and humidity

- Do not install FS16Z fixtures in a location where water can pool around the fixture or allow FS16Z fixtures to become submerged in any other way. Do not aim low- or high-pressure water jets at fixtures.
- Keep all unused connectors on the fixture sealed with their protective caps, both when the fixture is being used and when it is not in use.
- In outdoor and high-humidity environments, use IP65-rated power and data connectors and cable (an IP65 rating means that the item is protected against the entry of water from rain, projections and low-pressure jets as well as the entry of dust). When assembling connectors and installing them on cable, follow the manufacturer's instructions (see [www.neutrik.com](http://www.neutrik.com)) and ensure that an IP65 rating is maintained for the complete assembly. Use only the following cable connectors:
  - IP65-rated 5-pin XLR connectors for data IN and OUT (THRU)
  - Neutrik powerCON TRUE1 NAC3FX-W for Power IN
  - Neutrik powerCON TRUE1 NAC3MX-W for Power OUT (THRU).
- Apply a dielectric grease (available from electrical suppliers) to connector terminals and caps to prevent corrosion and/or electrical short circuits.
- Make sure that cables open into dry areas or sealed junction boxes. Moisture can be drawn along cables by capillary action or pressure variations resulting from thermal expansion.
- See drawing on right. Arrange cables so that they arrive at connectors from below. Make sure that it is impossible for water to flow down cables and accumulate at connectors. If necessary, provide extra cable slack and create 'drip loops' before connectors.

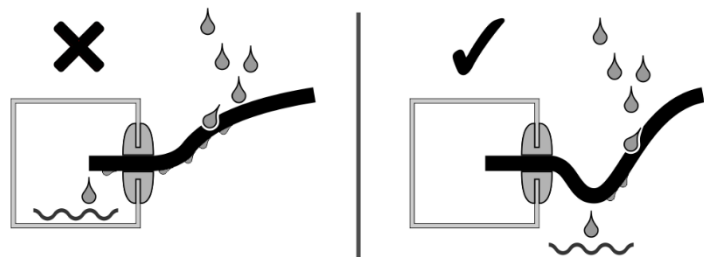

- Create loose cable bends only. Do not subject connections to bending forces or allow connections to bear the weight of long lengths of cable.

### **Avoiding damage from dust and airborne particles**

- Carry out regular visual inspections of the fixture to make sure that there is no accumulation of dirt, especially on the front of the fixture.
- If cleaning is necessary, follow the instructions in 'Service' on page 43.

### **Transportation and storage**

- If fixtures have been fastened together with locking pins, remove the pins and separate the fixtures before transport. Do not transport fixtures that are fastened together, or shocks during transport will expose fixtures to leverage forces and may cause damage that is not covered by the product warranty.
- Transport the fixture in its original packaging to protect it from damage caused by shocks during transportation.
- Store the fixture in a dry location when not in use.

### **GLP Service and Support**

Contact information for the nearest GLP Service and Support is available online at [www.glp.de/en/service](http://www.glp.de/en/service), by email at [info@glp.de](mailto:info@glp.de), or by telephone at the following numbers:

- GLP Germany: +49 (7248) 927 19-55
- GLP N. America: +1 818 767-8899
- GLP UK: +44 1392 690140
- GLP Asia: +852 (3151) 7730
- GLP Nordic: +46 737 57 11 40



### 3. FS16Z overview

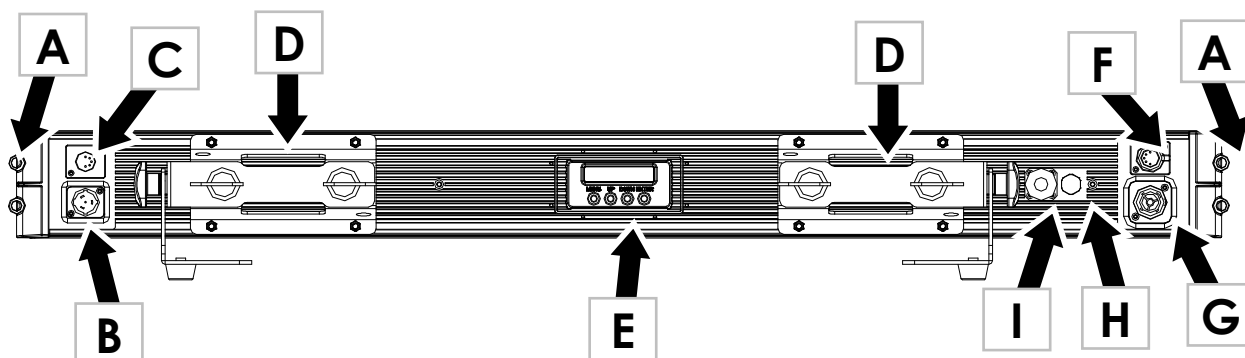

*Figure 2. FS16Z overview*

- A – End bracket / side-to-side fastening points**
- B – AC mains power IN (Neutrik powerCON TRUE1)**
- C – DMX IN (5-pin XLR)**
- D – Mounting bracket with quarter-turn fasteners**
- E – Control panel with OLED display**
- F – DMX OUT/THRU (5-pin XLR)**
- G – AC mains power OUT/THRU (Neutrik powerCON TRUE1)**
- H – Pressure equalization valve**
- I – Mounting point for optional WDMX antenna**





## 4. Installation



**Warning!** Read 'Safety' starting on page 5 for important safety information that you must understand before you install or operate the fixture. Install FS16Z fixtures only as described in this chapter, or you may create an installation that is unsafe.

Install the fixture at least 0.2 m / 8 in. away from combustible materials (wood, textiles, paper, etc.), 0.2 m / 8 in. away from any surface that will be illuminated, and a safe distance away from any flammable materials (volatile spirits, etc.).

When fixtures are used outside, monitor wind and weather conditions constantly. Clear the area of members of the public immediately and take the installation down (if safe to do so) if forecast or observed meteorological conditions create any risk that the installation may become unstable or dangerous in any other way.

It is the installer's responsibility to provide a stable, secure supporting structure that is suitable for the environment and application and that meets all applicable codes and legal requirements. Note the requirement to secure lighting fixtures with safety cables in temporary installations.

### Permitted Mounting options

An FS16Z fixture may be installed in one of the following ways:

1. Standing horizontally on a horizontal surface using two FS16Z Tilt Brackets as a floorstand.
2. Standing vertically on a horizontal surface using an FS16Z End Adapter Set and an FS16Z Base Plate.
3. Fastened to a surface at any angle by means of two FS16Z Tilt Brackets.
4. Fastened to a rigging truss or similar structure at any angle by means of two rigging clamps and two FS16Z Clamp Brackets (optional accessories).
5. Suspended vertically from a rigging truss or similar structure by means of an FS16Z Vertical Suspension Bracket and a rigging clamp or rigging eyelet (optional accessories).
6. Hanging from another FS16Z fixture vertically suspended to form a column.

(Please read 'Vertical hanging safety information' on page 23 before linking fixtures together)

## Securing fixtures with a safety cable

In temporary installations, if a fixture can cause injury or damage if it falls you must secure it with a secondary attachment such as a safety cable that will hold it if the primary means of attachment fails. The safety cable must be approved for the weight that it secures. In multiple installations, each fixture must have its own safety cable.

To secure an FS16Z fixture with a safety cable, attach the cable through the hole **A** in one of the rear fixing brackets:

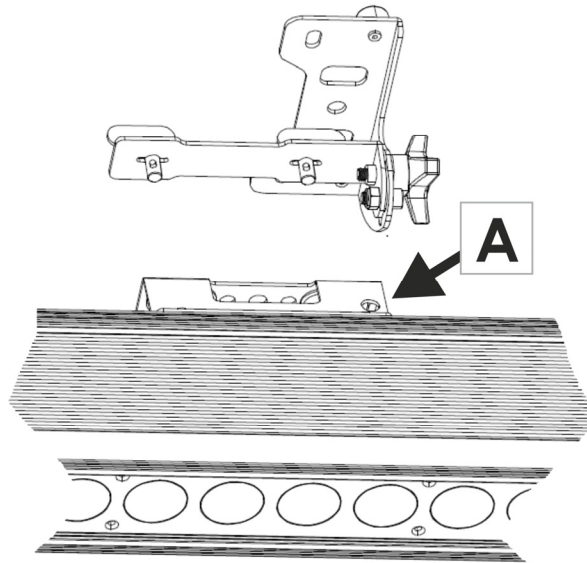

**Figure 3. Safety cable attachment point**

1. Loop a safety cable around a secure anchoring point such as a truss chord or fixed structure so that it will catch the fixture if a rigging clamp fails. Take up as much slack as possible in the safety cable (by looping it more than once around the truss chord, for example).
2. See Figure 3. Fasten the safety cable to the attachment hole **A** in one of the brackets on the back of the fixture. Check that the fixture is now secured.

## Attaching mounting brackets to the fixture

A pair of tilt brackets for fastening the fixture to a surface at any angle or placing the fixture on a horizontal surface is supplied with the FS16Z. Clamp brackets for fastening rigging clamps to the fixture are available as optional accessories.

To mount either a pair of Clamp Brackets or a pair of Tilt Brackets on the back of a fixture:

1. See figure 4. Push the bracket into the fastener mounting holes on the rear of the fixture.
2. Turn both quarter-turn fastener handles on each bracket through a full 90 degrees clockwise to lock the brackets to the fixture. Ensure the fasteners are fully locked in position before rigging the fixture.

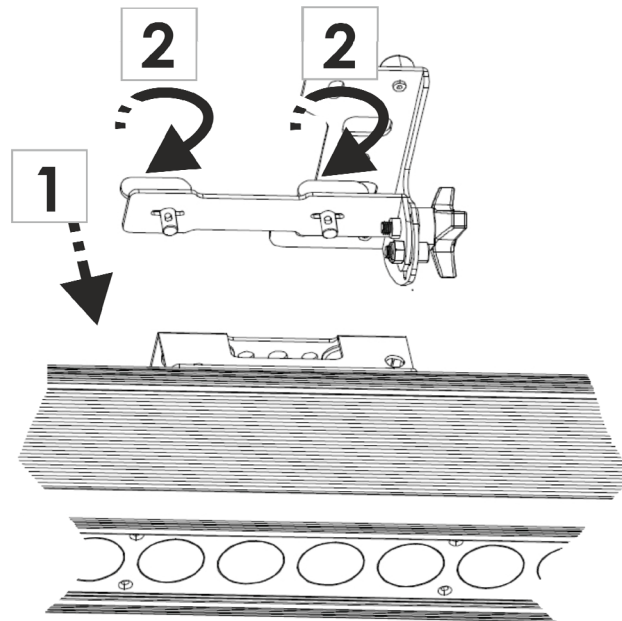

**Figure 4. Attaching adjustable bracket to fixture**

### Using FS16Z Locking Pins

The FS16Z system includes Locking Pins that can be pushed into channels in the ends of fixtures to lock them to each other or to installation hardware.

To install a Locking Pin:

1. See Figure 5. Push button **A** and keep it pressed in while you insert the pin into the channels.
2. When the pin is fully inserted, release button **A**. This will lock the retaining ball **B** in the 'out' position and prevent the pin from sliding or being pulled out of the channels.
3. To remove the pin, press button **A** and pull the pin out using the flange.

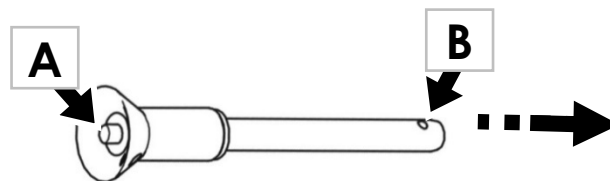
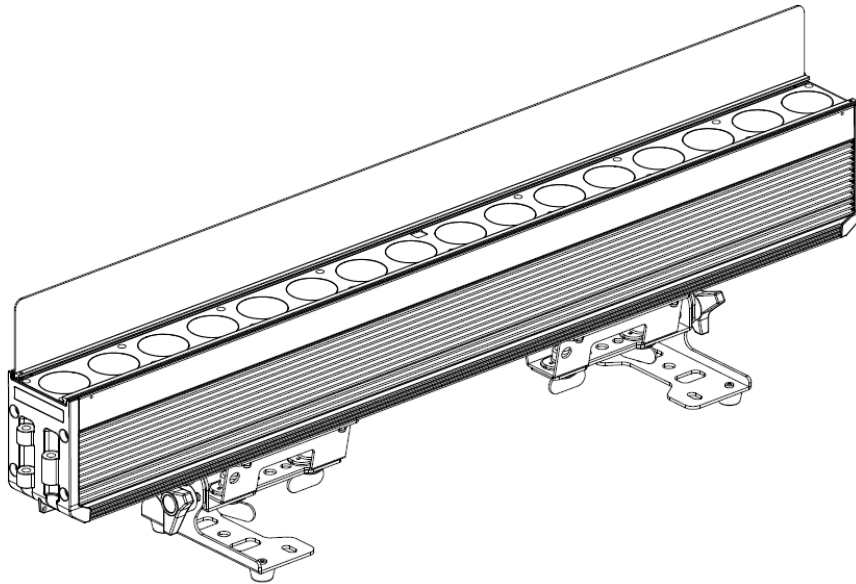

**Figure 5. Locking Pin**

Please read 'Vertical hanging safety information' on page 23 before linking fixtures together.

### **Standing horizontally on a surface**

The FS16Z fixture can stand horizontally on the floor or other stable, horizontal surface.



**Figure 6. FS16Z standing horizontally (shown with glare shield installed)**

To stand the FS16Z fixture horizontally:

1. Install two FS16Z Tilt Brackets on the fixture as described in 'Attaching mounting brackets to the fixture' on page 18.
2. Loosen the handwheels on the brackets, adjust the brackets to a suitable angle as shown in Figure 6 and tighten the handwheels.
3. Place the fixture on the surface. Make sure that it is safe and secure, and that it will not present a danger of tripping or falling.

For instructions on installing an FS16Z fixture standing vertically on a horizontal surface, see 'Vertical installation standing on a surface' on page 26.

## Installing on a rigging truss or similar structure

You can suspend an FS16Z fixture from a rigging truss or pipe using either the fixture's adjustable Tilt Brackets or the Clamp Brackets that are available from GLP as optional accessories for the FS16Z. It is also possible to directly fix rigging clamps to the rear mountings on the fixture without attaching either of the brackets.

If you are going to install the fixture hanging underneath a horizontal rigging truss or pipe, you can fasten it to the truss using G-clamps. If you are going to install the fixture in any other orientation (such as clamped above the truss), you must use half-coupler clamps that completely surround the truss chord or pipe.

### Installing on a truss using Tilt Brackets

To install the FS16Z on a rigging truss or pipe using rigging clamps and the Tilt Brackets supplied with the fixture:

1. Check that the truss or pipe is secure and can safely hold the weight of fixtures, hardware and cables.
2. Fasten two Tilt Brackets to the back of the fixture as described in as described in 'Attaching mounting brackets to the fixture' on page 18.
3. Fasten two rigging clamps that are approved for the weight of the fixture to the Tilt Brackets using two M12 bolts, grade 8.8 steel or better, that pass through the holes arrowed in Figure 7.

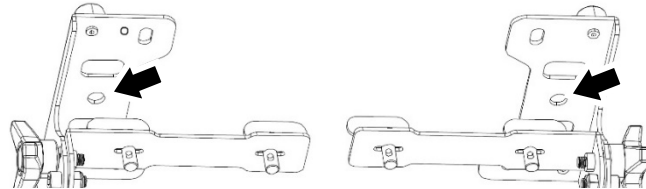

**Figure 7. Holes for bolting rigging clamps to Tilt Brackets**

4. Hold the fixture up to the truss chord, pass the rigging clamps around the truss chord, then tighten the clamps to install the fixture securely on the truss.
5. In temporary installations, secure each fixture with a safety cable as described in '' on page 18 if there is any risk that the fixture will cause injury or damage if it falls.

### Installing on a truss using Clamp Brackets

To install the FS16Z on a rigging truss or pipe using rigging clamps and optional Clamp Brackets:

1. Check that the truss or pipe is secure and can safely hold the weight of fixtures, hardware and cables.
2. See Figure 8. Bolt two rigging clamps **A** (G-clamps shown) that are approved for the weight of the fixture to two Clamp Brackets **B**.

3. Fasten the Clamp Brackets **B** to the mounting plates on the back of the fixture as shown in Figure 8, inserting the quarter-turn fasteners and then turning the quarter-turn fastener handles **C** a full 90° clockwise to lock them.

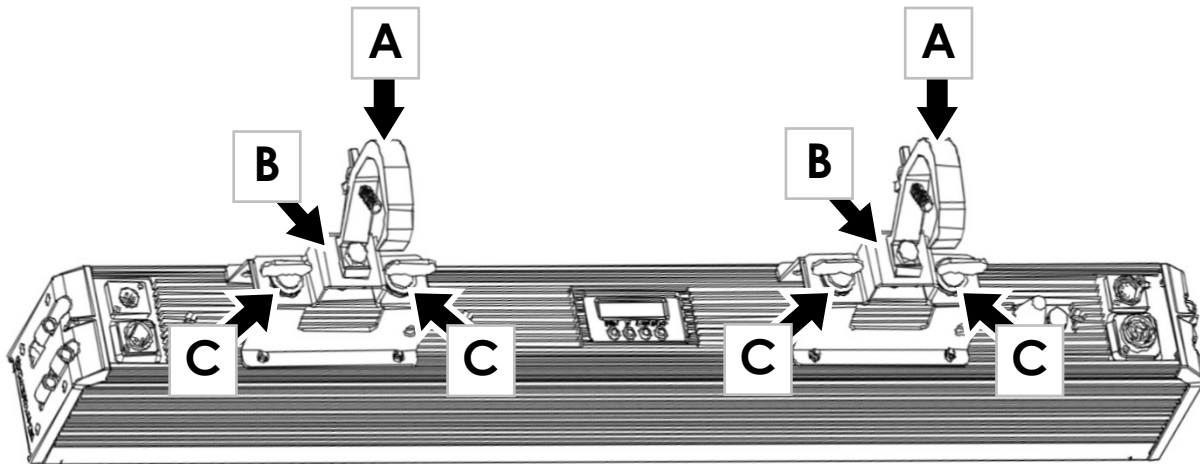
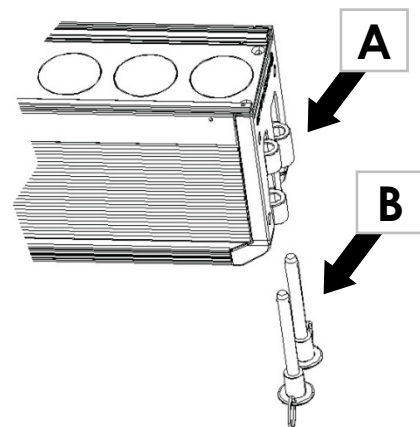

**Figure 8. Clamp Brackets and rigging clamps**

4. Hold the fixture up to the truss chord, pass the rigging clamps around the truss chord, then tighten the clamps to install the fixture securely on the truss.
5. In temporary installations, secure each fixture with a safety cable as described in 'Securing fixtures with a safety cable' on page 18 if there is any risk that the fixture will cause injury or damage if it falls.

### Side-to-side attachment

See Figure 9. Locking channels **A** at both ends of FS16Z fixtures accept FS16Z locking pins **B**. This feature lets you align fixtures to each other quickly and accurately to form an unbroken line of pixels.



**Figure 9. End channels and locking pins**



**Warning!** Do not use the locking channels and pins to support the weight of fixtures unless the fixtures are hanging vertically one above the other. If fixtures are not hanging vertically, each individual fixture must be supported by fastening it securely to a surface or structure as directed in this chapter, and the locking pins may be used for alignment purposes only

## Vertical suspension from a rigging structure

You can install the FS16Z hanging vertically downwards from a rigging structure if you use the FS16Z Hanging Adaptor (optional accessory), which fixes into the locking channels at the ends of the fixture.

Using the end channels and locking pins, you can suspend FS16Z fixtures from each other in an interconnected vertical chain to give an unbroken line of pixels.

For hanging one fixture or a chain of two fixtures, you may use rigging clamps. Otherwise you should use a pair of M10 or M12 rigging eyelets with suitably rated cables, to hang up to six fixtures. This allows for the higher loading and gives some flexibility for movement of the fixture column, which would damage or break rigging clamps.

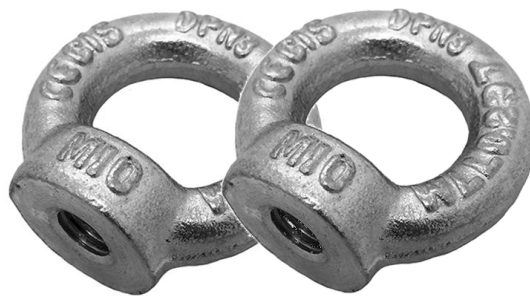

**Figure 10. M10 rigging eyelets**

Please see the next section 'Suspending multiple fixtures vertically' and refer to the safety information below.

### Vertical hanging safety information



**Warning!** You can use locking pins and channels in fixtures to support weight only when fixtures are fastened together in a vertical chain – do not use them to support the weight of a fixture at any other angle than hanging vertically downwards.

**Warning!** When using the Hanging Adaptor with rigging clamps, do not link more than **two (2) fixtures** to each other in one suspended vertical chain.

When suspended using cables and rigging eyelets, up to **six (6) fixtures** may be linked and suspended in a vertical chain.

**Warning!** Any lateral force applied to the bottom of a suspended column of FS16Z fixtures can apply leveraged force to the suspension hardware and cause it to fail. This will cause the column to fall resulting in death, serious injury or damage.

Always lock the bottom of the column in place with cables or other hardware so that it is impossible for any pressure applied by wind, persons, vibration, etc. to move the bottom of the column.

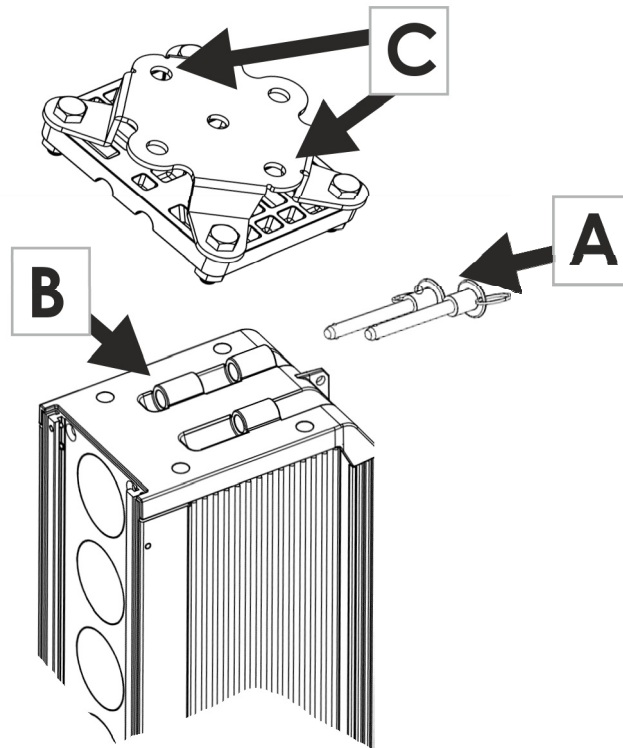
**Installing the FS16Z Hanging Adaptor on a fixture****Figure 11. Hanging Adapter**

1. See Figure 11. Place the Hanging Adaptor on the end of the fixture so that the locking pin channels **B** in the end plate and the fixture mesh with each other.
2. Push the two locking pins **A** into the channels in the End Plate and the fixture so that the Hanging Adaptor and fixture are locked together. Press the button on each pin so that you can push the pin fully into its channel.
3. When the pin is fully engaged, release the button and check that the pin is now locked in place.
4. Attach rigging clamps or eyelets which are suitable for the weight of the fixture(s) to the holes **C** in the Hanging Adaptor. For hanging one or two fixtures in a chain, use two clamps to prevent the fixture from turning. For hanging more than two fixtures in a chain, use two M10 or M12 rigging eyelets with suitably rated cables.
6. As soon as you suspend the fixture from a truss using the rigging clamp, install a safety cable as described in 'Attaching mounting brackets to the fixture' on page 18 if there is any risk that the fixture will cause injury or damage if it falls.



### ***Suspending multiple fixtures vertically***

To create a hanging vertical chain:

1. Suspend the first fixture as described in 'Vertical suspension from a rigging structure' on page 23. Check that the installation will be safe and that the rigging clamp and safety cable are approved for the total weight of all the fixtures in the chain. If you intend to hang more than two fixtures, use M10 or M12 rigging eyelets and cables to suspend the first fixture instead of a rigging clamp.
2. See Figure 12. Have two FS16Z Locking Pins **A** ready.
3. Lift the second fixture up to the first so that the locking channels **B** in the fixtures mesh with each other.
4. Push the two locking pins **A** into the channels **B** in both fixtures. Press the button on each locking pin so that you can push the pin fully into its channel. When the pin is fully engaged, release the button and check that the button is in the fully out position so that the pin is locked in place. Check that the pins now lock the two fixtures together.
5. If required by locally applicable regulations, secure the second fixture by using a safety cable to fasten the safety cable attachment eyelets in the brackets on the back of the first and second fixtures to each other so that the safety cable will catch the second fixture if it falls. In some regions (where DGUV-215-313 is applicable, for example) the use of two independent locking pins means that use of a safety cable is not required.
6. If you have suspended the first fixture using cables and rigging eyelets, you can continue fastening fixtures to each other up to six (6) fixtures in total. If using fixed rigging clamps, only two (2) fixtures may be linked.

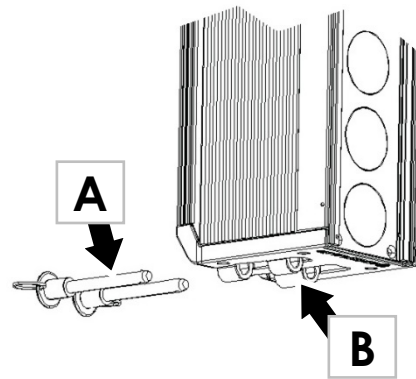
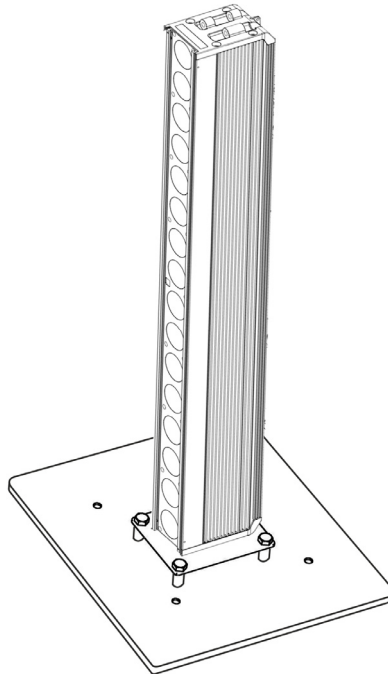

**Figure 12. Locking pins used for creating a vertical chain**

***Wherever possible, fix the bottom end of the fixture chain in place using cables or other hardware to prevent movement which could cause damage to and failure of the fixing at the top of the chain.***

## Vertical installation standing on a surface

You can install one or two FS16Z fixtures standing vertically on a stable horizontal surface as shown in Figure 13 using the FS16Z Base Plate adaptor which is an optional accessory.



**Figure 13. FS16Z installed on FS16Z Base Plate**



**Warning!** You can install a maximum of two fixtures standing vertically by this method. Make sure that there is no danger of fixtures falling over.

To create a vertical column of more than two fixtures, you can:

- attach the FS16Z base plate to a safely dimensioned F34 truss steel base plate
- fasten each fixture individually to a vertical truss, or
- suspend a chain of up to six (6) fixtures from a horizontal truss as described in 'Suspending multiple fixtures vertically' on page 25.

To install an FS16Z fixture standing vertically:

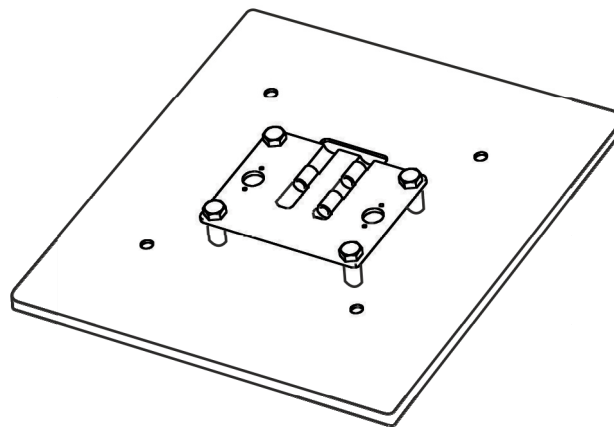

**Figure 14. Base Plate accessory**

1. See Figure 14. Place the End Plate accessory on the end of the fixture, rotating it if necessary so that the locking channels in the end of the fixture mesh correctly with the corresponding channels in the End Plate.
2. Fasten the fixture to the End Plate / Base Plate assembly by pushing two locking pins fully into the locking channels in the End Plate and in the fixture. Release the buttons in the locking pins and ensure the pins are locked in position.
3. Place the fixture on the surface. Make sure that it is safe and secure, and that it will not present a danger of tripping or falling.
4. If there is a risk that the fixture may fall over and cause injury or damage, fasten the Base Plate to the surface using suitable bolts or screws passed through the four holes in the corners of the plate, or attach a steel F32 truss base plate. Make sure that it is impossible for the fixture to fall or be knocked over.
6. To install a second fixture on top of the first fixture, see Figure 15. Have two Locking Pins ready to fasten the fixtures together.

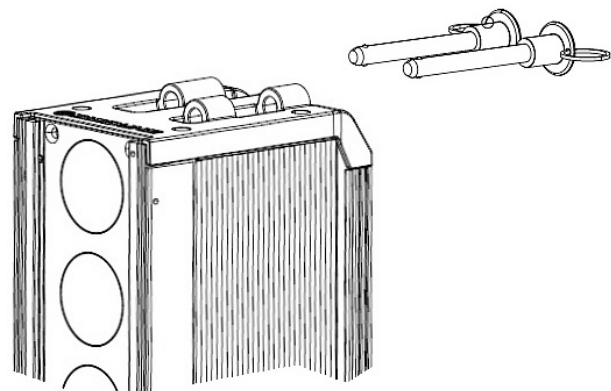

**Figure 15. Locking pins ready for second fixture standing vertically**

7. Lower the second fixture onto the first fixture oriented so that the locking channels in both fixtures mesh correctly. Then press the buttons on the Locking Pins and press them fully into the locking channels before releasing the buttons.
8. Check that both Locking Pins are locked into position and that the fixtures are fastened securely together.
9. Make sure that it is impossible for the two fixtures to fall or be knocked over. If the arrangement is not completely safe, secure it with a safety cable or reinstall the fixtures using a larger F34 truss base plate.

## 5. AC mains power



**Warning!** Read 'Safety' starting on page 5 for important safety information that you must understand before you install or operate the fixture.

Check that all cables and connectors are suitable for the installation environment and application (see recommendations in 'Avoiding damage to the fixture' on page 11).

Use H07 RN-F 3 x 2.5mm / SJT 12 AWG cables with original Neutrik powerCON TRUE1 connectors to supply power to fixtures.

Line up the keyways in connectors carefully. Do not try to insert or twist a connector if it feels excessively stiff. Resistance to insertion or twisting is a sign that connectors may be incorrectly lined up.

Keep connectors sealed with their rubber caps at all times when not in use.

### Included items

The FS16Z is supplied with a power cord with Neutrik powerCON TRUE1 connector.

### Connecting to power

The AC mains power supply must include a connection to ground / protective earth. It must be protected against ground / earth leakage and overload. The fixture's internal auto-sensing power supply accepts AC power at 100-240 V, 50/60 Hz. Do not connect the fixture to power at any other voltage or to an external dimmer.

The FS16Z does not have a power ON/OFF switch. Power is applied to the fixture as soon as the power cable becomes live.

The FS16Z has a 3-conductor Neutrik powerCON TRUE1 Mains IN power input socket that accepts AC power from a TRUE1 female cable connector. Although TRUE1 connectors support hot plugging, it is still good practice to shut down power to power cables before connecting them to fixtures.

To connect the fixture to power:

1. If convenient, shut down power to the power input cable.
2. Note the position of the keys and keyways on the TRUE1 power cable connector and Mains IN socket and align them with each other. Insert the cable connector into the socket and twist clockwise to lock. Do not use force. If the connector feels excessively stiff, remove it and check again that it is lined up correctly.
3. Before applying power to the power cable, check that nobody is looking directly into the front of the fixture.

To disconnect the fixture from power, pull the latch on the cable connector outwards to release it, then twist the connector counterclockwise and pull to remove it from the socket.

## Installing power connectors

If you intend to draw power from convenience receptacles / consumer mains power sockets, it is possible to install a suitable cord cap / power plug on the supplied power cord / input cable. If you do this, check that the cord cap / plug is rated minimum 250 V, 16 A, that it has a connection to ground / earth and that it has an integral cable grip. Follow the cord cap / plug manufacturer's assembly instructions.

If you need to install a Neutrik powerCON TRUE1 connector on a power cable, follow the instructions given in the Support area of the Neutrik website at [www.neutrik.com](http://www.neutrik.com).

Respect the color coding used in the supplied power cable and in your local mains power wiring system. US and EU systems use the color coding shown below:

	Live or L	Neutral or N	Ground / Earth or ⊕
<b>US system</b>	Black	White	Green
<b>EU system</b>	Brown	Blue	Yellow/green

## Connecting multiple fixtures to power in a chain

You can connect fixtures to power in a daisy-chain to simplify your power circuit layout.

FS16Z fixtures have 2.5 mm<sup>2</sup> internal wiring from Power IN to Power THRU connectors.



**Warning!** Do not connect more than three (3) FS16Z fixtures in total to power in one chain at 100-120 V, 60 Hz. Do not connect more than six (6) FS16Z fixtures in total to power in one chain at 200-240 V, 50 Hz.

The power input cable supplied with the fixture is rated 16 A maximum. Add together the maximum current draw ratings of all the devices that you intend to connect to power in a daisy chain and do not create a chain with a total maximum current draw of more than 16 A, or you will create a risk of fire and electric shock.

To connect fixtures to power in a chain:

1. Obtain power relay cables that have male and female Neutrik powerCON TRUE1 connectors. Cables must be minimum 14 AWG or 1.5mm<sup>2</sup>, rated minimum 16 A and suitable for the environment and application.
2. Connect the power input cable to the Mains IN socket of the first fixture as described under 'Connecting to power' on page 29.
3. Connect a relay cable to the Mains OUT / THRU socket of the first fixture and to the Mains IN socket of the second fixture.
4. If you are using 100-120 V, 60 Hz AC mains power you can continue connecting FS16Z fixtures Mains OUT / THRU socket to Mains IN socket until the chain contains a maximum of three (3) fixtures in total. If you are using 200-240 V, 50 Hz AC mains power you can continue connecting fixtures Mains OUT to Mains IN until the chain contains a maximum of six (6) fixtures total.

## 6. Connecting to DMX data

Check that all cables and connectors are suitable for the installation environment and application (see recommendations in 'Avoiding damage to the fixture' on page 11).

Use digital 110 Ohm DMX cable with IP65 5-pin XLR connectors to supply DMX data to fixtures.

Keep connectors sealed with their rubber caps at all times when not in use.

The FS16Z has two 5-pin XLR connectors for IN and THRU connections to a DMX data link. FS16Z fixtures support the USITT DMX 512A signal protocol. They also support RDM (Remote Device Management).

The 5-pin XLR connectors use standard pin allocations:

1	Signal Ground
2	Data -
3	Data +
4	Not used
5	Not used

If you would like advice with planning and installing a DMX link, your GLP supplier will be happy to provide assistance.

## 7. Features

The Fusion Stick FS16Z from GLP is a powerful LED-based strobe/color effect linear lighting fixture.

The fixture features sixteen 20 watt RGBW LEDs with a motorized zoom producing a powerful beam with an 8° to 40° beam angle. The LEDs can be controlled together or individually depending on the DMX control mode selected. Each LED is surrounded by a halo diffuser ring to provide excellent visibility even at acute angles.

You can run a wide range of color effects (including strobe effects running at up to 20 Hz and dynamic FX patterns) on the LEDs, or you can operate them continuously using RGBW color mixing.

A separate CTO DMX channel is available (depending on the fixture's DMX control mode), letting you quickly adjust the warmth of the white light output.

Fixtures can be interlocked end-to-end to form longer arrays, and power and data can be daisy-chained for ease of installation.

The FS16Z can be used indoors in permanent and temporary installations. Its rugged construction and IP65 rating mean that it can also be used outdoors in temporary installations if precautions are taken to prevent immersion in water and damage from direct sunlight. It can be placed upright on a level surface or suspended from a suitable structure as described in the fixture's Quick Start and Installation Manual.

Four mounting points with M3 threaded holes are provided on the front of FS16Z fixtures for mounting optical accessories from GLP.

The FS16Z is not suitable for household use, for use in any location where unattended children have access to it, or for use in permanent outdoor installations.

### Zoom

The FS16Z's motorized optical zoom allows you to change the beam angle from a narrow 8° flat beam effect to a 40° wash effect.

### Color wheel effect

The FS16Z's virtual color wheel gives you quick access to a range of LEE-referenced color presets.

### RGBW color mixing

You can use RGBW color mixing to set a custom color or to fine-tune a color preset that you have selected on the Color wheel channel.

16-bit RGBW color mixing is available in Advanced DMX Mode.

### Shutter effect

The FS16Z's electronic shutter effect provides ramp up and down effects and a variable speed strobe as well as instant blackout.



## Dimming

See Figure 16. You can select from four dimming curves using the control panel or the *Control / Settings* DMX channel:

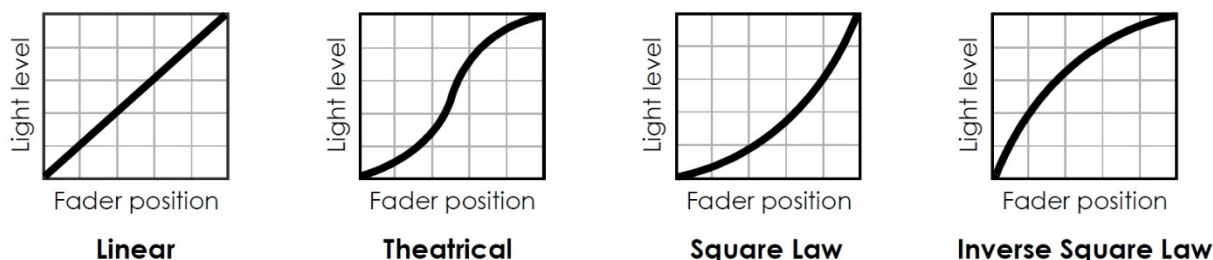

**Figure 16. Dimming curves**

- **Linear** sets dimming so that it appears to increase and decrease evenly throughout the dimming range.
- **Theatrical** is an S-shaped curve that gives finer control at low and at high light levels.
- **Square Law** gives finer control at low light levels and coarser control at high light levels.
- **Inverse Square Law** gives coarser control at low light levels and finer control at high light levels.

The default setting is **Linear**.

## Patterns

The FS16Z's pre-programmed patterns give you quick access to a wide range of static and dynamic patterns with a range of movement options.

See the section '14. Guide to patterns' on page 62 for tables showing the appearance of the patterns.

### **Single-layer pattern control**

The following DMX Modes provide control of one layer of patterns on three DMX channels

- Mode 1 – Standard
- Mode 2 – Advanced

In these modes, the DMX channels are laid out as follows:

- The first channel lets you select a pattern.
- The second channel lets you adjust movement speed if you have selected an animated pattern.

- The third channel – pattern fading – lets you soften the edges of animated patterns by setting each pixel to fade up and down as it is deployed in the pattern.

If you run a pattern, it will take priority over whatever you are displaying using the standard channels and appear to be superimposed on top of them.

### **Two-level pattern control**

DMX Mode 2 gives two superimposable layers of patterns. Each of the two layers has its own separate speed, crossfading, shutter and dimmer adjustment channels. Each layer also has its own RGBW color control on four channels.

If you run a Pattern 1, it will take priority over whatever you are displaying using the standard channels and appear to be superimposed on top of them.

If you run a Pattern 2, it will take priority over the background channels and Pattern 1 and appear to be superimposed on top of everything that the fixture is displaying.

### **Behavior when the fixture is not receiving a DMX signal**

You can set the fixture to react in three different ways if no DMX signal is present (if the fixture is being controlled by DMX but the DMX signal stops, or if you apply power to the fixture when no DMX signal is present):

- **Hold** sets the fixture to continue obeying the last DMX values it received. This is the default setting.

If no DMX signal was being received, the fixture will black out.

- **Blackout** sets the fixture to black out.
- **Stand-alone** sets the fixture to show the scene that has been stored using *Capture scene* (see below). For safety reasons and to avoid unwanted surprises, the Stand-alone scene will always fade in slowly if it is activated.

To program the scene that the fixture will display if it is set to Stand-alone and no DMX signal is present, use the *Capture scene* command:

- **Capture scene** stores the scene that the fixture is currently displaying. Once stored, the scene is used as the fixture's *Stand-alone* scene.

All these settings are available via DMX on the *Control / Settings* channel and in the fixture's control panel.

To avoid any possibility of unexpected behavior from a powerful strobe light if the DMX signal fails, we recommend that you always set the fixture to *Blackout*.

### **Display**

The illuminated graphic OLED display lets you change fixture settings when power is applied. See Chapters 9 and 10 for more details.

Using the *Control / Settings* DMX channel or the fixture's control panel you can:

- Change the display orientation from Normal to Inverted for easier reading if the fixture is flown upside-down in a rig.
- Choose between three different display modes:

- **Auto:** The display will automatically switch off after a few seconds if the fixture is receiving a valid control signal and has not detected an error. If the fixture is not receiving a valid control signal the display will flash. If the fixture has detected an error, the display will remain constantly on and show the error.
- **On:** The display stays on constantly. This setting can be useful when you are configuring or servicing the fixture.
- **Off:** The display will automatically switch off after a few seconds even if the fixture is not receiving a valid control signal or if it has detected an error.

## Fixture information

The **Information** menu in the control panel gives access to items of information from the fixture's sensors and memory. You can check temperature sensor readouts, see total operating hours counters and power cycle count, and see DMX signal quality data, for example.

## Custom settings and factory defaults

You can customize fixture settings (DMX mode, Pixel orientation, etc.) via DMX or using the fixture's control panel. Custom settings are stored after a power off/on cycle and after a reset.

Two options are available in the fixture's control panel for deleting multiple custom settings and restoring defaults:

- **Load Setting Defaults** reloads all the fixture's factory default settings **except** DMX address, DMX mode and Control protocol. This option returns the fixture to baseline settings (default Fan mode, Output limitation, Pixel orientation, Dimmer curve, etc.) without affecting its basic configuration in an installation.
- **Load Factory Backup** reloads all the fixture's factory default settings **including** DMX address, DMX mode and Control Protocol. This option reinitializes the fixture completely and returns to its state when it left the factory.

## 8. IR Remote









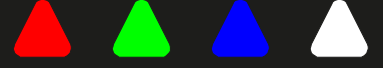

An infrared remote control is available as an optional accessory for the FS16Z.

By default, the fixture gives priority to commands received via DMX and will ignore commands sent by the IR remote if it is receiving a DMX signal. If you want the fixture to give priority to commands from the IR remote, set **IR Priority** in the **Personality** menu is set to **ON**. If you have used the IR remote and want to return to DMX control, hold the "Black" button for 5 seconds to go back to DMX.

The receiver for commands from the IR remote is located in the center of the front surface of the fixture.

The IR remote is powered by a button-cell battery. If the remote seems to have stopped working the battery may be discharged. Replace it with a new item.

The IR remote offers these functions:

	Increase color intensity
	Toggle color on 100% / off 0 %
	Reduce color intensity
	Select a color preset
	
	
	
	Increase speed / intensity (see note 1)
	Decrease speed / intensity (see note 1)
	Select an internal program from the three programs created in <b>Stand-Alone</b> → <b>Program Edit</b>
	Set a program to run a chase, pause a program, fade out or black out

Note 1: "Speed" arrows control the zoom when no pattern is running.

## 9. Control menus and onboard display



**Warning!** DMX control is disabled when the control menus are active. Be prepared for the fixture to emit strong light as soon as you exit the control menus.

The control panel and onboard OLED display provide access to user settings, readouts and utilities.

DMX addr. 1 - 17  
Advanced

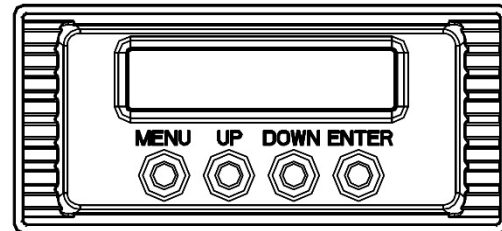

**Figure 17. Onboard display**

The four control buttons have the following functions:

**MENU:** Activate the menus or go back one level towards the top of the menu.

**UP:** Scroll up or increase a number.

**DOWN:** Scroll down or reduce a number.

**ENTER:** Activate the control panel if it is in sleep mode. Then enter a menu, select a setting or implement a command.

When you apply power to the fixture, it boots up. After it has booted, the panel displays the default screen.

See Figure 17. The default screen displays the fixture's DMX mode and the DMX channels that the fixture occupies (in Figure 17, the fixture is in Advanced DMX mode. It has DMX address 1 and occupies DMX channels 1 – 17. DMX channel 18 is available for the next fixture on the DMX link)

DMX control is disabled when the control menus are active.

See also the Display options on the *DMX Control / Settings* channel and in the *Display* control menu in the control panel.

## 10. Control menu layout

### Menus

### Notes

DMX			
Address	1 - 512		Enter DMX address
Mode	Standard - 12		Select DMX control mode
	Advanced - 33		
	Pixel - 79		
	Compressed RGBW - 6		
	Compressed Pixel - 69		
RDM	On / Off		Enable / Disable RDM functionality
Reset via DMX	On / Off		Enable / Disable fixture resetting via DMX
No DMX	<b>Shutter Closed</b>		Blackout when no DMX signal is received
	Hold		Hold current scene when no DMX signal is received
	Play Program 1		Play stored stand-alone program 1 when no DMX signal is received
	Play Program 2		Play stored stand-alone program 2 when no DMX signal is received
	Play Program 3		Play stored stand-alone program 3 when no DMX signal is received
W-DMX (if optional wireless DMX accessory installed)	Mode	<b>Off</b>	Wireless DMX disabled
		Receive	Receive wireless DMX
		Transmit	Transmit wireless DMX
	Connection	Link	Link / unlink transmitter and receiver
		Unlink	
DMX Live	Refresh rate	XXX Hz	Display current DMX signal refresh rate
	Color wheel	0 - 255	Display DMX values being received for each effect
	Red	0 - 255	
	... Pattern fade	... 0 - 255	
Personality			
Dimmer Curve	<b>Linear</b>		Select dimming curve
	Theatrical		
	Square Law		
	Inverse Square		
Dimmer Speed	<b>Fast</b>		Dimmer optimized for speed
	Smooth		Dimmer optimized for smoothness

PWM	600 Hz			Sets the pulse-width modulation (flicker) frequency of the LED dimming
	<b>1200 Hz</b>			
	2400 Hz			
	4800 Hz			
	9600 Hz			
Display Setting	Shutoff time	<b>Off</b>		Display sleep mode disabled: display remains on permanently
		1 minute		Display goes into sleep mode after 1 / 5 / 60 minutes
		5 minute		
	No signal flash	<b>On</b>		Enable / Disable flashing display if no DMX signal is received
		Off		
	Flip display	<b>Auto</b>		Display automatically inverts if fixture is inverted
		Off		Display normal
On		Display inverted		
Temperature Unit	<b>Celsius</b>			Set temperature units used in display
	Fahrenheit			
Lock	<b>Off</b>			Enable / disable password requirement for access to control menus
	On			
	Set password	XXXX	XXXX	Set a custom password for access to control menus
Boot Mode	Select Mode	Auto		At power on, fixture returns to last action before power off, but any new DMX commands take priority
		DMX		At power on, fixture waits for DMX signal
		Static Program		At power on, fixture shows the scene programmed in Static Mode (see below) even if the fixture is receiving DMX commands.
	DMX High Priority	<b>On / Off</b>		If enabled, DMX signal always takes priority no matter which action is set for power on
IR Priority	<b>Off / On</b>			If enabled, IR remote takes priority over DMX signal
Reverse LED	<b>Off / On</b>			If enabled, reverses the LED positions

Stand-Alone					
Test Sequence	Run / <b>Cancel</b>		Run sequence that tests all colors and all LEDs		
Master / Slave	<b>Alone</b>		Independent stand-alone operation (fixture does not act as Master or Slave).		
	Master		Sends out all 3 internal programs to DMX link if you run any program		
	Slave	<b>Slave 1</b>	Slave 1 plays Program 1 sent by a Master device, Slave 2 plays Program 2, Slave 3 plays Program 3		
		Slave 2			
Slave 3					
Static Mode	Color wheel	0 - 255		Set fixture to display a static color and pattern	
	Red	0 - 255			
	Green	0 - 255			
	Blue	0 - 255			
	White	0 - 255			
	Shutter	0 - <b>255</b>			
	Dimmer	0 - <b>255</b>			
	Zoom	0 - <b>255</b>			
	CTO	0 - 255			
	Pattern	0 - 255			
	Pattern Speed	0 - 255			
	Pattern Fade	0 - 255			
		Reset All	Yes / No		Set all <b>Static Mode</b> values to defaults (Shutter and Dimmer = 255, all other values = 0)
Program Edit	Program 1	Prog1 Steps	Select Step	01-30	Select step to program from Step 1 to Step 30
			Capture DMX	<b>Yes / Cancel</b>	Capture current DMX values as scene for current step in program 1
			Color Wheel	0 - 255	Set DMX value for each effect that you want to use in current scene
			Red	0 - 255	
			Green	0 - 255	
			Blue	0 - 255	
			White	0 - 255	
			Shutter	0 - 255	
			Dimmer	0 - 255	
			Zoom	0-255	
			CTO	0 - 255	
			Reset All	<b>No / Yes</b>	Reset all effects values to zero
			Hold Time	000 - 99	Set time in seconds that scene is held
			Fade Time	000 - 99	Set time in seconds for scene to crossfade into next



	Program 2	Prog 2 Steps	...	Same as Program 1 (see above)
	Program 3	Prog 3 Steps	...	Same as Program 1 (see above)
Program Play	Program 1		<b>No</b> / Yes	Play one of the Programs created in <b>Program Edit</b>
	Program 2		<b>No</b> / Yes	
	Program 3		<b>No</b> / Yes	
	Program All		<b>No</b> / Yes	Play consecutively all of the Programs created in <b>Program Edit</b>
Program Reset	Program 1		<b>No</b> / Yes	Delete one of the Programs created in <b>Program Edit</b>
	Program 2		<b>No</b> / Yes	
	Program 3		<b>No</b> / Yes	
	Program All		<b>No</b> / Yes	Delete all of the Programs created in <b>Program Edit</b>

Service				
Reset	Fixture Reset		Reset / <b>Cancel</b>	Reset all motors in fixture
	Zoom Reset		Reset / <b>Cancel</b>	Reset zoom mechanism
Calibration	Enable			Set fixture to run with factory calibration settings
	<b>Disable</b>			Set fixture to run in uncalibrated mode
	Color Offset	Red	0 - 255	Enter maximum value for each color. Values are saved as custom calibration settings that are unaffected by power off/on cycles. Custom values are deleted if Factory defaults are loaded
		Green	0 - 255	
		Blue	0 - 255	
		White	0 - 255	
	Motor fine (password 0088)	Motor 1	0 - 255	Offset the default zoom motor position.
Motor 2		0 - 255		
Motor 3		0 - 255		
Motor 4		0 - 255		
W-DMX Installed	<b>No</b> / Yes		Enable use of wireless DMX accessory (when installed)	
Factory default	<b>No</b> / Yes		Return all settings to factory default values except W-DMX setting	
Fixture Time	Resettable	XXX hours	View resettable power-on hours counter	
	Total	XXX hours	View total (non-resettable) power-on hours counter	
	Clear Resettable	Clear / Cancel	Clear resettable power-on hours counter	
Fixture Temp.	Actual	XXX C / XXX F	View current fixture temperature	
	Max	XXX C / XXX F	View resettable maximum temperature log	
	Reset Max	Clear / Cancel	Clear resettable maximum temperature log	
Firmware Version	X.X.X.X		View currently installed firmware version	
Serial Number	(Password: 6307) 220401XXXXX		View fixture's serial number	

### Control Menus

Default settings are written in **BOLD type**.



**Warning!** There are no user-serviceable parts inside the fixture. Opening the fixture can compromise its IP65 rating and cause damage that is not covered by the product warranty. Any service operation that requires removal of a cover must be performed by a professional service technician with the tools, skills, and personal protective equipment to maintain high-powered lighting equipment safely and efficiently.

## 11. Service

### Cleaning

FS16Z fixtures require occasional cleaning to prevent the buildup of dust, dirt, and residue from atmospheric effects. Failure to keep the fixture clean will significantly reduce light output and may cause heat buildup and damage that is not covered by the product warranty. Regular cleaning will ensure maximum performance and reliable operation.

The cleaning schedule depends on the operating environment. Check fixtures regularly for signs of dirt buildup.

You can clean the fixture using a soft cloth slightly dampened with a household or automotive glass cleaning product. Do not apply pressure to the clear front or display on the back of the fixture, as you may scratch these surfaces.

### Installing a glare shield

The FS16Z is supplied with a glare shield that can be installed on the front of the fixture to reduce lateral light spill if required.

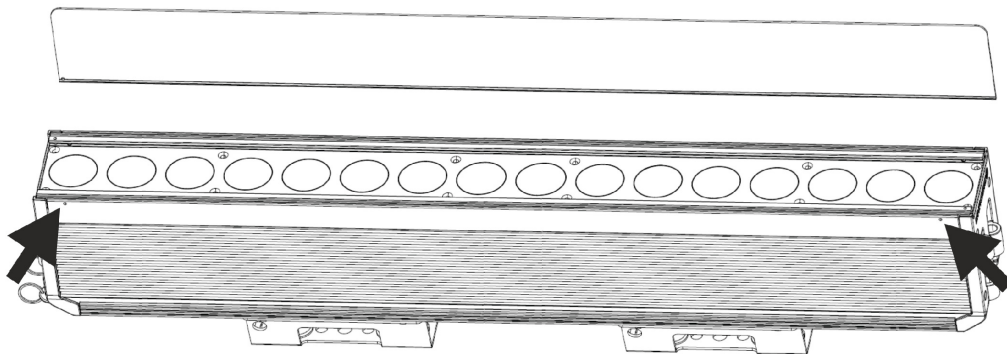

**Figure 18. FS16Z Glare Shield**

To install a Glare Shield:

1. See Figure 18. Slide the Glare Shield into the channel provided on the side of the fixture where you want to prevent light spill.
2. Insert the two supplied grub screws into the threaded holes (arrowed) in the sides of the fixture and tighten them until they grip the Glare Shield firmly.

## Installing a diffuser

20°, 40°, 60° and 10°x60° (asymmetric) diffusers that can be installed over the front of the fixture to soften the light output are available as optional accessories for the FS16Z.

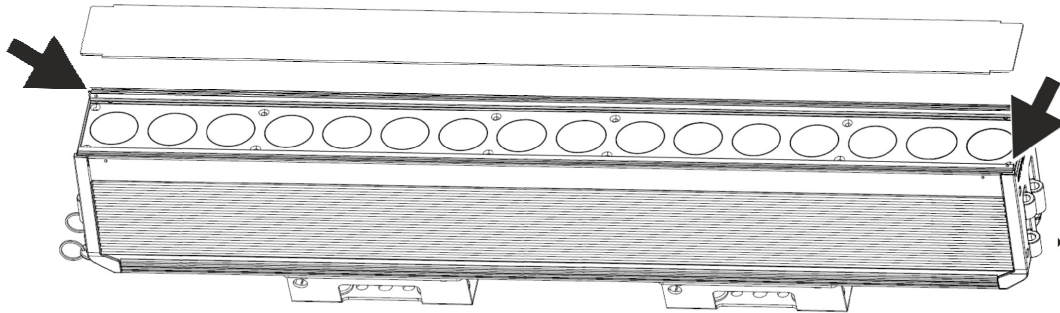

**Figure 19. FS16Z Diffuser**

To install an FS16Z Diffuser:

1. See Figure 19. Slide the diffuser into the provided channels on the front of the fixture. A spring-loaded ball detent system will hold the diffuser in place.
2. If the fixture is installed horizontally on a surface, securing the diffuser with screws is not necessary, but if the fixture is installed at any other angle than horizontal, it may be possible for the diffuser to slide out of the fixture and cause injury or damage. In this case, insert the two grub screws supplied with diffusers into the threaded holes (arrowed) in the front face of the fixture at diagonal corners of the diffuser and screw them tight.
3. Check that the grub screws now prevent the diffuser from sliding out of the front of the fixture.

## GLP Service and Support

Contact information for the nearest GLP Service and Support is available online at [www.glp.de/en/service](http://www.glp.de/en/service), by email at [info@glp.de](mailto:info@glp.de), or by telephone at the following numbers:

- GLP Germany: +49 (7248) 927 19-55
- GLP N. America: +1 818 767-8899
- GLP UK: +44 1392 690140
- GLP Asia: +852 (3151) 7730
- GLP Nordic: +46 737 57 11 40

## 12. DMX control modes overview

The following DMX control modes are available in the FS16Z.

### DMX Mode 1: Standard (14 channels)

provides a virtual color wheel (color presets) and RGBW color mixing. A separate Shutter channel provides strobe, pulse and ramp-up/down effects and a Master dimmer provides 16-bit control of overall intensity.

Zoom control is available, and the fixture offers color temperature control on a separate CTO channel. A wide range of pre-programmed static and animated patterns are available. The animated patterns have variable movement speed and crossfading speed.

A Control / Settings channel lets you configure the fixture remotely via DMX.

#### Mode 1 Standard

1	Color wheel
2	Red
3	Green
4	Blue
5	White
6	Shutter
7	Master dimmer
8	Master dimmer fine
9	Zoom
10	CTO
11	Pattern select
12	Pattern speed
13	Pattern fade
14	Control/Settings

### DMX Mode 2: Advanced (33 channels)

provides a virtual color wheel (color presets) and 16-bit RGBW color mixing. A separate Shutter channel provides strobe, pulse and ramp-up/down effects and a Master dimmer provides 16-bit control of overall intensity.

Zoom control is available, and the fixture offers color temperature control on a separate CTO channel. Mode 2 offers two layers of effects, each with a wide range of pre-programmed static and animated patterns, RGBW color mixing, shutter effects and variable intensity. The animated patterns in both layers also have variable movement speed and crossfading speed.

A Control / Settings channel lets you configure the fixture remotely via DMX.

Mode 2 Advanced	
--------------------	--

1	Color wheel
2	Red
3	Red fine
4	Green
5	Green fine
6	Blue
7	Blue fine
8	White
9	White fine
10	Shutter
11	Master dimmer
12	Master dimmer fine
13	Zoom
14	CTO
15	Pattern 1 select
16	Pattern 1 speed
17	Pattern 1 fade
18	Pattern 1 Red
19	Pattern 1 Green
20	Pattern 1 Blue
21	Pattern 1 White
22	Pattern 1 shutter
23	Pattern 1 dimmer
24	Pattern 2 select
25	Pattern 2 speed
26	Pattern 2 fade
27	Pattern 2 Red
28	Pattern 2 Green
29	Pattern 2 Blue
30	Pattern 2 White
31	Pattern 2 shutter
32	Pattern 2 dimmer
33	Control/Settings

**DMX Mode 3: Pixel (79 channels)**

provides a virtual color wheel (color presets) and 16-bit RGBW color mixing. A separate Shutter channel provides strobe, pulse and ramp-up/down effects and a 16-bit Master dimmer channel controls overall intensity.

Zoom control is available, and the fixture offers color temperature control on a separate CTO channel.

This mode also offers individual pixel-level RGBW color mixing.

A Control / Settings channel lets you configure the fixture remotely via DMX.

**Mode 3  
Pixel**

1	Color wheel
2	Red
3	Red fine
4	Green
5	Green fine
6	Blue
7	Blue fine
8	White
9	White fine
10	Shutter
11	Master dimmer
12	Master dimmer fine
13	Zoom
14	CTO
15	Pixel 1 Red
16	Pixel 1 Green
17	Pixel 1 Blue
18	Pixel 1 White
19	Pixel 2 Red
20	Pixel 2 Green
21	Pixel 2 Blue
22	Pixel 2 White
...	...
...	Pixels RGBW in sequence
...	...
75	Pixel 16 Red
76	Pixel 16 Green
77	Pixel 16 Blue
78	Pixel 16 White
79	Control / Settings

**DMX Mode 4: Compressed RGBW**

provides the main control options: RGBW color mixing, zoom control and a Control / Settings channel that lets you configure the fixture via DMX.

**Mode 4  
Compressed RGBW**

1	Red
2	Green
3	Blue
4	White
5	Zoom
6	Control / Settings

**DMX Mode 5: Compressed Pixel (69 channels)** provides individual pixel-level RGBW color mixing, with overall intensity and shutter control.

Mode 5 Compressed Pixel	
----------------------------	--

1	Shutter
2	Master dimmer
3	Master dimmer fine
4	Zoom
5	Control / Settings
6	Pixel 1 Red
7	Pixel 1 Green
8	Pixel 1 Blue
9	Pixel 1 White
10	Pixel 2 Red
11	Pixel 2 Green
12	Pixel 2 Blue
13	Pixel 2 White
...	...
...	Pixels RGBW in sequence
...	...
66	Pixel 16 Red
67	Pixel 16 Green
68	Pixel 16 Blue
69	Pixel 16 White





### 13. DMX control channel layout

In the following DMX channel layout tables:

- Default settings are indicated with **bold type**.
- Where commands are marked with an asterisk \* you must send that value continuously for 3 seconds (or other duration if indicated in the table) to apply the command.
- Where LED orientation commands are marked with two asterisks \*\* the direction of FX pattern *movement* is reversed compared to the similar commands available earlier on the same channel. The FX pattern *orientation* is unchanged.

**DMX Mode 1: Standard**

**14 DMX Channels**

Channel	Command	DMX range	Percent	Default DMX	Fade
1	No function: RGBW color mixing	0-5	0-2.0%	0	Snap
	LEE 790 - Moroccan Pink	6-10	2.4-3.9%		
	LEE 157 - Pink	11-15	4.3-5.9%		
	LEE 332 - Special Rose Pink	16-20	6.3-7.8%		
	LEE 328 - Follies Pink	21-25	8.2-9.8%		
	LEE 345 - Fuchsia Pink	26-30	10.2-11.8%		
	LEE 194 - Surprise Pink	31-35	12.2-13.7%		
	LEE 181 - Congo Blue	36-40	14.1-15.7%		
	LEE 071 - Tokyo Blue	41-45	16.1-17.6%		
	LEE 120 - Deep Blue	46-50	18.0-19.6%		
	LEE 079 - Just Blue	51-55	20.0-21.6%		
	LEE 132 - Medium Blue	56-60	22.0-23.5%		
	LEE 200 - Double CT Blue	61-65	23.9-25.5%		
	LEE 161 - Slate Blue	66-70	25.9-27.5%		
	LEE 201 - Full CT Blue	71-75	27.8-29.4%		
	LEE 202 - Half CT Blue	76-80	29.8-31.4%		
	LEE 117 - Steel Blue	81-85	31.8-33.3%		
	LEE 353 - Lighter Blue	86-90	33.7-35.3%		
	LEE 118 - Light Blue	91-95	35.7-37.3%		
	LEE 116 - Medium Blue Green	96-100	37.6-39.2%		
	LEE 124 - Dark Green	101-105	39.6-41.2%		
	LEE 139 - Primary Green	106-110	41.6-43.1%		
	LEE 089 - Moss Green	111-115	43.5-45.1%		
	LEE 122 - Fern Green	116-120	45.5-47.1%		
	LEE 738 - JAS Green	121-125	47.5-49.0%		
	LEE 088 - Lime Green	126-130	49.4-51.0%		
	LEE 100 - Spring Yellow	131-135	51.4-52.9%		
	LEE 104 - Deep Amber	136-140	53.3-54.9%		
	LEE 179 - Chrome Orange	141-145	55.3-56.9%		
	LEE 105 - Orange	146-150	57.3-58.8%		
	LEE 021 - Gold Amber	151-155	59.2-60.8%		
	LEE 778 - Millennium Gold	156-160	61.2-62.7%		
	LEE 135 - Deep Golden Amber	161-165	63.1-64.7%		
	LEE 164 - Flame Red	166-170	65.1-66.7%		
	Color wheel rotation forwards fast-slow	171-185	67.1-72.5%		
	Color wheel stops at current color	186-190	72.9-74.5%		
	Color wheel rotation backwards fast-slow	191-205	74.9-80.4%		
	Color wheel stops at current color	206-210	80.8-82.4%		
	Random colors fast-slow	211-225	82.7-88.2%		
	Tungsten simulation	226-230	88.6-90.2%		
Warm white - 3200K	231-235	90.6-92.2%			
Neutral white - 4200K	236-240	92.5-94.1%			
Cool white - 5600K	241-245	94.5-96.1%			
Cool white - 7200K	246-250	96.5-98.0%			
Cool white - 8000K	251-255	98.4-100%			

<b>2</b>	<b>Red</b>	Intensity 0-100%	0-255	0-100%	0	Fade
<b>3</b>	<b>Green</b>	Intensity 0-100%	0-255	0-100%	0	Fade
<b>4</b>	<b>Blue</b>	Intensity 0-100%	0-255	0-100%	0	Fade
<b>5</b>	<b>White</b>	Intensity 0-100%	0-255	0-100%	0	Fade
<b>6</b>	<b>Shutter</b>	Shutter closed	0-15	0-5.9%	0	Snap
		Random strobe	16-47	6.3-18.4%		
		Ramp up slow-fast	48-79	18.8-31.0%		
		Ramp down slow-fast	80-111	31.4-43.5%		
		Ramp up-down slow-fast	112-143	43.9-56.1%		
		Strobe pause 5s – 1s (slow – fast)	144-199	56.5-78.0%		
		Strobe 1Hz – 20 Hz (slow – fast)	200-239	78.4-93.7%		
	Shutter open	240-255	94.1-100%			
<b>7</b>	<b>Dimmer</b>	Intensity 0-100% (16-bit)	0-255	0-100%	0	Fade
<b>8</b>	<b>Dimmer fine</b>		0-255	0-100%	0	Fade
<b>9</b>	<b>Zoom</b>	Narrow – Wide	0-255	0-100%	0	Fade
<b>10</b>	<b>CTO</b>	Color temperature cool-warm	0-255	0-100%	0	Fade
<b>11</b>	<b>Pattern selection</b> See 'Guide to patterns' on page 62	No Pattern – all pixels lit	0-5	0-2.0%	0	Snap
		Static Patterns	6-79	2.4-3.1%		
		Animated Patterns	80-179	31.4-70.2%		
		No function	180-255	70.6-100%		
<b>12</b>	<b>Pattern speed</b>	Pattern speed slow-fast	0-255	0-100%	0	Fade
<b>13</b>	<b>Pattern fade</b>	Pattern intensity 0-100%	0-255	0-100%	0	Fade
<b>14</b>	<b>Control / Settings</b>	See 'Control / Settings channel' on page 60.				

**DMX Mode 2: Advanced****33 DMX Channels**

Channel	Command	DMX range	Percent	Default DMX	Fade	
1	Color wheel	No function: RGBW color mixing	0-5	0-2.0%	0	Snap
		LEE 790 - Moroccan Pink	6-10	2.4-3.9%		
		LEE 157 - Pink	11-15	4.3-5.9%		
		LEE 332 - Special Rose Pink	16-20	6.3-7.8%		
		LEE 328 - Follies Pink	21-25	8.2-9.8%		
		LEE 345 - Fuchsia Pink	26-30	10.2-11.8%		
		LEE 194 - Surprise Pink	31-35	12.2-13.7%		
		LEE 181 - Congo Blue	36-40	14.1-15.7%		
		LEE 071 - Tokyo Blue	41-45	16.1-17.6%		
		LEE 120 - Deep Blue	46-50	18.0-19.6%		
		LEE 079 - Just Blue	51-55	20.0-21.6%		
		LEE 132 - Medium Blue	56-60	22.0-23.5%		
		LEE 200 - Double CT Blue	61-65	23.9-25.5%		
		LEE 161 - Slate Blue	66-70	25.9-27.5%		
		LEE 201 - Full CT Blue	71-75	27.8-29.4%		
		LEE 202 - Half CT Blue	76-80	29.8-31.4%		
		LEE 117 - Steel Blue	81-85	31.8-33.3%		
		LEE 353 - Lighter Blue	86-90	33.7-35.3%		
		LEE 118 - Light Blue	91-95	35.7-37.3%		
		LEE 116 - Medium Blue Green	96-100	37.6-39.2%		
		LEE 124 - Dark Green	101-105	39.6-41.2%		
		LEE 139 - Primary Green	106-110	41.6-43.1%		
		LEE 089 - Moss Green	111-115	43.5-45.1%		
		LEE 122 - Fern Green	116-120	45.5-47.1%		
		LEE 738 - JAS Green	121-125	47.5-49.0%		
		LEE 088 - Lime Green	126-130	49.4-51.0%		
		LEE 100 - Spring Yellow	131-135	51.4-52.9%		
		LEE 104 - Deep Amber	136-140	53.3-54.9%		
		LEE 179 - Chrome Orange	141-145	55.3-56.9%		
		LEE 105 - Orange	146-150	57.3-58.8%		
		LEE 021 - Gold Amber	151-155	59.2-60.8%		
		LEE 778 - Millennium Gold	156-160	61.2-62.7%		
		LEE 135 - Deep Golden Amber	161-165	63.1-64.7%		
LEE 164 - Flame Red	166-170	65.1-66.7%				
Color wheel rotation forwards fast-slow	171-185	67.1-72.5%				
Color wheel stops at current color	186-190	72.9-74.5%				
Color wheel rotation backwards fast-slow	191-205	74.9-80.4%				
Color wheel stops at current color	206-210	80.8-82.4%				
Random colors fast-slow	211-225	82.7-88.2%				
Tungsten simulation	226-230	88.6-90.2%				
Warm white - 3200K	231-235	90.6-92.2%				
Neutral white - 4200K	236-240	92.5-94.1%				
Cool white - 5600K	241-245	94.5-96.1%				

		Cool white - 7200K	246-250	96.5-98.0%		
		Cool white - 8000K	251-255	98.4-100%		
<b>2</b>	<b>Red</b>	Intensity 0-100% (16-bit)	0-255	0-100%	0	Fade
<b>3</b>	<b>Red fine</b>		0-255	0-100%	0	Fade
<b>4</b>	<b>Green</b>	Intensity 0-100% (16-bit)	0-255	0-100%	0	Fade
<b>5</b>	<b>Green fine</b>		0-255	0-100%	0	Fade
<b>6</b>	<b>Blue</b>	Intensity 0-100% (16-bit)	0-255	0-100%	0	Fade
<b>7</b>	<b>Blue fine</b>		0-255	0-100%	0	Fade
<b>8</b>	<b>White</b>	Intensity 0-100% (16-bit)	0-255	0-100%	0	Fade
<b>9</b>	<b>White fine</b>		0-255	0-100%	0	Fade
<b>10</b>	<b>Shutter</b>	Shutter closed	0-15	0-5.9%	0	Snap
		Random strobe	16-47	6.3-18.4%		
		Ramp up slow-fast	48-79	18.8-31.0%		
		Ramp down slow-fast	80-111	31.4-43.5%		
		Ramp up-down slow-fast	112-143	43.9-56.1%		
		Strobe pause 5s – 1s (slow – fast)	144-199	56.5-78.0%		
		Strobe 1Hz – 20 Hz (slow – fast)	200-239	78.4-93.7%		
	Shutter open	240-255	94.1-100%			
<b>11</b>	<b>Dimmer</b>	Master intensity 0-100% (16-bit)	0-255	0-100%	0	Fade
<b>12</b>	<b>Dimmer fine</b>		0-255	0-100%	0	Fade
<b>13</b>	<b>Zoom</b>	Narrow – Wide	0-255	0-100%	0	Fade
<b>14</b>	<b>CTO</b>	Color temperature cool-warm	0-255	0-100%	0	Fade
<b>15</b>	<b>Pattern 1 selection</b> <i>See 'Guide to patterns' on page 62</i>	No Pattern – all pixels lit	0-5	0-2.0%	0	Snap
		Static Patterns	6-79	2.4-3.1%		
		Animated Patterns	80-179	31.4-70.2%		
		No function	180-255	70.6-100%		
<b>16</b>	<b>Pattern 1 speed</b>	Pattern 1 speed slow-fast	0-255	0-100%	0	Fade
<b>17</b>	<b>Pattern 1 fade</b>	Pattern 1 intensity 0-100%	0-255	0-100%	0	Fade
<b>18</b>	<b>Pattern 1 Red</b>	Intensity 0-100%	0-255	0-100%	0	Fade
<b>19</b>	<b>Pattern 1 Green</b>	Intensity 0-100%	0-255	0-100%	0	Fade
<b>20</b>	<b>Pattern 1 Blue</b>	Intensity 0-100%	0-255	0-100%	0	Fade
<b>21</b>	<b>Pattern 1 White</b>	Intensity 0-100%	0-255	0-100%	0	Fade
<b>22</b>	<b>Pattern 1 Shutter</b>	Shutter closed	0-15	0-5.9%	0	Snap
		Random strobe	16-47	6.3-18.4%		
		Ramp up slow-fast	48-79	18.8-31.0%		
		Ramp down slow-fast	80-111	31.4-43.5%		
		Ramp up-down slow-fast	112-143	43.9-56.1%		
		Strobe pause 5s – 1s (slow – fast)	144-199	56.5-78.0%		
		Strobe 1Hz – 20 Hz (slow – fast)	200-239	78.4-93.7%		
	Shutter open	240-255	94.1-100%			
<b>23</b>	<b>Pattern 1 Dimmer</b>	Intensity 0-100%	0-255	0-100%	0	Fade
<b>24</b>	<b>Pattern 2 selection</b> <i>See 'Guide to patterns' on page 62</i>	No Pattern – all pixels lit	0-5	0-2.0%	0	Snap
		Static Patterns	6-79	2.4-3.1%		
		Animated Patterns	80-179	31.4-70.2%		
		No function	180-255	70.6-100%		
<b>25</b>	<b>Pattern 2 speed</b>	Pattern 2 speed slow-fast	0-255	0-100%	0	Fade
<b>26</b>	<b>Pattern 2 fade</b>	Pattern 2 intensity 0-100%	0-255	0-100%	0	Fade
<b>27</b>	<b>Pattern 2 Red</b>	Intensity 0-100%	0-255	0-100%	0	Fade
<b>28</b>	<b>Pattern 2 Green</b>	Intensity 0-100%	0-255	0-100%	0	Fade
<b>29</b>	<b>Pattern 2 Blue</b>	Intensity 0-100%	0-255	0-100%	0	Fade
<b>30</b>	<b>Pattern 2 White</b>	Intensity 0-100%	0-255	0-100%	0	Fade

<b>31</b>	<b>Pattern 2 Shutter</b>	Shutter closed	0-15	0-5.9%	0	Snap
		Random strobe	16-47	6.3-18.4%		
		Ramp up slow-fast	48-79	18.8-31.0%		
		Ramp down slow-fast	80-111	31.4-43.5%		
		Ramp up-down slow-fast	112-143	43.9-56.1%		
		Strobe pause 5s – 1s (slow – fast)	144-199	56.5-78.0%		
		Strobe 1Hz – 20 Hz (slow – fast)	200-239	78.4-93.7%		
		Shutter open	240-255	94.1-100%		
<b>32</b>	<b>Pattern 2 Dimmer</b>	Intensity 0-100%	0-255	0-100%	0	Fade
<b>33</b>	<b>Control / Settings</b>	See 'Control / Settings channel' on page 60.				

## DMX Mode 3: Pixel

### 79 DMX Channels

Channel	Command	DMX range	Percent	Default DMX	Fade	
1	Color wheel	No function: RGBW color mixing	0-5	0-2.0%	0	Snap
	LEE 790 - Moroccan Pink	6-10	2.4-3.9%			
	LEE 157 - Pink	11-15	4.3-5.9%			
	LEE 332 - Special Rose Pink	16-20	6.3-7.8%			
	LEE 328 - Follies Pink	21-25	8.2-9.8%			
	LEE 345 - Fuchsia Pink	26-30	10.2-11.8%			
	LEE 194 - Surprise Pink	31-35	12.2-13.7%			
	LEE 181 - Congo Blue	36-40	14.1-15.7%			
	LEE 071 - Tokyo Blue	41-45	16.1-17.6%			
	LEE 120 - Deep Blue	46-50	18.0-19.6%			
	LEE 079 - Just Blue	51-55	20.0-21.6%			
	LEE 132 - Medium Blue	56-60	22.0-23.5%			
	LEE 200 - Double CT Blue	61-65	23.9-25.5%			
	LEE 161 - Slate Blue	66-70	25.9-27.5%			
	LEE 201 - Full CT Blue	71-75	27.8-29.4%			
	LEE 202 - Half CT Blue	76-80	29.8-31.4%			
	LEE 117 - Steel Blue	81-85	31.8-33.3%			
	LEE 353 - Lighter Blue	86-90	33.7-35.3%			
	LEE 118 - Light Blue	91-95	35.7-37.3%			
	LEE 116 - Medium Blue Green	96-100	37.6-39.2%			
	LEE 124 - Dark Green	101-105	39.6-41.2%			
	LEE 139 - Primary Green	106-110	41.6-43.1%			
	LEE 089 - Moss Green	111-115	43.5-45.1%			
	LEE 122 - Fern Green	116-120	45.5-47.1%			
	LEE 738 - JAS Green	121-125	47.5-49.0%			
	LEE 088 - Lime Green	126-130	49.4-51.0%			
	LEE 100 - Spring Yellow	131-135	51.4-52.9%			
	LEE 104 - Deep Amber	136-140	53.3-54.9%			
	LEE 179 - Chrome Orange	141-145	55.3-56.9%			
	LEE 105 - Orange	146-150	57.3-58.8%			
	LEE 021 - Gold Amber	151-155	59.2-60.8%			
	LEE 778 - Millennium Gold	156-160	61.2-62.7%			
	LEE 135 - Deep Golden Amber	161-165	63.1-64.7%			
	LEE 164 - Flame Red	166-170	65.1-66.7%			
	Color wheel rotation forwards fast-slow	171-185	67.1-72.5%			
	Color wheel stops at current color	186-190	72.9-74.5%			
	Color wheel rotation backwards fast-slow	191-205	74.9-80.4%			
	Color wheel stops at current color	206-210	80.8-82.4%			
	Random colors fast-slow	211-225	82.7-88.2%			
	Tungsten simulation	226-230	88.6-90.2%			
Warm white - 3200K	231-235	90.6-92.2%				
Neutral white - 4200K	236-240	92.5-94.1%				
Cool white - 5600K	241-245	94.5-96.1%				
Cool white - 7200K	246-250	96.5-98.0%				



		Cool white - 8000K	251-255	98.4-100%		
<b>2</b>	<b>Red</b>	Intensity 0-100% (16-bit)	0-255	0-100%	0	Fade
<b>3</b>	<b>Red fine</b>		0-255	0-100%	0	Fade
<b>4</b>	<b>Green</b>	Intensity 0-100% (16-bit)	0-255	0-100%	0	Fade
<b>5</b>	<b>Green fine</b>		0-255	0-100%	0	Fade
<b>6</b>	<b>Blue</b>	Intensity 0-100% (16-bit)	0-255	0-100%	0	Fade
<b>7</b>	<b>Blue fine</b>		0-255	0-100%	0	Fade
<b>8</b>	<b>White</b>	Intensity 0-100% (16-bit)	0-255	0-100%	0	Fade
<b>9</b>	<b>White fine</b>		0-255	0-100%	0	Fade
<b>10</b>	<b>Shutter</b>	Shutter closed	0-15	0-5.9%	0	Snap
		Random strobe	16-47	6.3-18.4%		
		Ramp up slow-fast	48-79	18.8-31.0%		
		Ramp down slow-fast	80-111	31.4-43.5%		
		Ramp up-down slow-fast	112-143	43.9-56.1%		
		Strobe pause 5s – 1s (slow – fast)	144-199	56.5-78.0%		
		Strobe 1Hz – 20 Hz (slow – fast)	200-239	78.4-93.7%		
		Shutter open	240-255	94.1-100%		
<b>11</b>	<b>Dimmer</b>	Master intensity 0-100% (16-bit)	0-255	0-100%	0	Fade
<b>12</b>	<b>Dimmer fine</b>		0-255	0-100%	0	Fade
<b>13</b>	<b>Zoom</b>	Narrow – Wide	0-255	0-100%	0	Fade
<b>14</b>	<b>CTO</b>	Color temperature cool-warm	0-255	0-100%	0	Fade
<b>15</b>	<b>Red Pixel 1</b>	Intensity 0-100%	0-255	0-100%	0	Fade
<b>16</b>	<b>Green Pixel 1</b>	Intensity 0-100%	0-255	0-100%	0	Fade
<b>17</b>	<b>Blue Pixel 1</b>	Intensity 0-100%	0-255	0-100%	0	Fade
<b>18</b>	<b>White Pixel 1</b>	Intensity 0-100%	0-255	0-100%	0	Fade
<b>19</b>	<b>Red Pixel 2</b>	Intensity 0-100%	0-255	0-100%	0	Fade
<b>20</b>	<b>Green Pixel 2</b>	Intensity 0-100%	0-255	0-100%	0	Fade
<b>21</b>	<b>Blue Pixel 2</b>	Intensity 0-100%	0-255	0-100%	0	Fade
<b>22</b>	<b>White Pixel 2</b>	Intensity 0-100%	0-255	0-100%	0	Fade
<b>23</b>	<b>Red Pixel 3</b>	Intensity 0-100%	0-255	0-100%	0	Fade
...	...	...				
<b>74</b>	<b>White Pixel 15</b>	Intensity 0-100%				
<b>75</b>	<b>Red Pixel 16</b>	Intensity 0-100%	0-255	0-100%	0	Fade
<b>76</b>	<b>Green Pixel 16</b>	Intensity 0-100%	0-255	0-100%	0	Fade
<b>77</b>	<b>Blue Pixel 16</b>	Intensity 0-100%	0-255	0-100%	0	Fade
<b>78</b>	<b>White Pixel 16</b>	Intensity 0-100%	0-255	0-100%	0	Fade
<b>79</b>	<b>Control / Settings</b>	See 'Control / Settings channel' on page 60.				

## DMX Mode 4: Compressed RGBW

### 6 DMX Channels

Channel	Command	DMX range	Percent	Default DMX	Fade	
1	<b>Red</b>	Intensity 0-100%	0-255	0-100%	0	Fade
2	<b>Green</b>	Intensity 0-100%	0-255	0-100%	0	Fade
3	<b>Blue</b>	Intensity 0-100%	0-255	0-100%	0	Fade
4	<b>White</b>	Intensity 0-100%	0-255	0-100%	0	Fade
5	<b>Zoom</b>	Shutter closed	0-15	0-5.9%	0	Snap
		Random strobe	16-47	6.3-18.4%		
		Ramp up slow-fast	48-79	18.8-31.0%		
		Ramp down slow-fast	80-111	31.4-43.5%		
		Ramp up-down slow-fast	112-143	43.9-56.1%		
		Strobe pause 5s – 1s (slow – fast)	144-199	56.5-78.0%		
		Strobe 1Hz – 20 Hz (slow – fast)	200-239	78.4-93.7%		
Shutter open	240-255	94.1-100%				
6	<b>Control / Settings</b>	See 'Control / Settings channel' on page 60.				

## DMX Mode 5: Compressed Pixel

### 69 DMX Channels

Channel	Command	DMX range	Percent	Default DMX	Fade	
1	Shutter	Shutter closed	0-15	0-5.9%	0	Snap
		Random strobe	16-47	6.3-18.4%		
		Ramp up slow-fast	48-79	18.8-31.0%		
		Ramp down slow-fast	80-111	31.4-43.5%		
		Ramp up-down slow-fast	112-143	43.9-56.1%		
		Strobe pause 5s – 1s (slow – fast)	144-199	56.5-78.0%		
		Strobe 1Hz – 20 Hz (slow – fast)	200-239	78.4-93.7%		
		Shutter open	240-255	94.1-100%		
2	Dimmer	Master intensity 0-100% (16-bit)	0-255	0-100%	0	Fade
3	Dimmer fine		0-255	0-100%	0	Fade
4	Zoom	Narrow – Wide	0-255	0-100%	0	Fade
5	Control / Settings	See 'Control / Settings channel' on page 60.				
6	Red Pixel 1	Intensity 0-100%	0-255	0-100%	0	Fade
7	Green Pixel 1	Intensity 0-100%	0-255	0-100%	0	Fade
8	Blue Pixel 1	Intensity 0-100%	0-255	0-100%	0	Fade
9	White Pixel 1	Intensity 0-100%	0-255	0-100%	0	Fade
10	Red Pixel 2	Intensity 0-100%	0-255	0-100%	0	Fade
11	Green Pixel 2	Intensity 0-100%	0-255	0-100%	0	Fade
12	Blue Pixel 2	Intensity 0-100%	0-255	0-100%	0	Fade
13	White Pixel 2	Intensity 0-100%	0-255	0-100%	0	Fade
14	Red Pixel 3	Intensity 0-100%	0-255	0-100%	0	Fade
...	...					
65	White Pixel 15	Intensity 0-100%				
66	Red Pixel 16	Intensity 0-100%	0-255	0-100%	0	Fade
67	Green Pixel 16	Intensity 0-100%	0-255	0-100%	0	Fade
68	Blue Pixel 16	Intensity 0-100%	0-255	0-100%	0	Fade
69	White Pixel 16	Intensity 0-100%	0-255	0-100%	0	Fade

## Control / Settings channel

Control / Settings						
14	Control / Settings	No function	0-55	0-21.6%	0	Snap
		Dimmer speed smooth*	56-60	22.0-23.5%		
		Dimmer speed fast*	61-65	23.9-25.5%		
		No function	66-70	25.9-27.5%		
		Dimming curve Linear*	71-75	27.8-29.4%		
		Dimming curve Theatrical*	76-80	29.8-31.4%		
		Dimming curve Square Law*	81-85	31.8-33.3%		
		Dimming curve Inverse Square Law*	86-90	33.7-35.3%		
		No Function	91-95	35.7-37.3%		
		No DMX = Hold scene*	96-100	37.6-39.2%		
		No DMX = Blackout*	101-105	39.6-41.2%		
		No DMX = Play Program 1*	106-110	41.6-43.1%		
		No Function	111-115	43.5-45.1%		
		Display backlight On*	116-120	45.5-47.1%		
		Display backlight Off*	121-125	47.5-49.0%		
		No Function	126-135	49.4-52.9%		
		DMX Mode: Standard*	136-140	53.3-54.9%		
		DMX Mode: Advanced*	141-145	55.3-56.9%		
		DMX Mode: Pixel*	146-150	57.3-58.8%		
		DMX Mode: Compressed RGBW*	151-155	59.2-60.8%		
		No function	156-175	61.2-68.6%		
		Zoom reset	176-180	69.0-70.6%		
		Fixture reset	181-185	71.0-72.5%		
		Factory default settings (except DMX address and DMX Mode)*	186-190	72.9-74.5%		
		No function	191-200	74.9-78.4%		
		PWM Rate: 600 Hz	201-205	78.8-80.4%		
		PWM Rate: 1200 Hz	206-210	80.8-82.4%		
		PWM Rate: 2000 Hz	211-215	82.7-84.3%		
		PWM Rate: 2400 Hz	216-220	84.7-86.3%		
		PWM Rate: 6000 Hz	221-225	86.7-88.2%		
		No function	226-230	88.6-90.2%		
		Boot Mode Auto*	231-235	90.6-92.2%		
Boot Mode DMX*	236-240	92.5-94.1%				
Boot Mode Play Program *	241-245	94.5-96.1%				
Boot Mode Static*	246-250	96.5-98.0%				
No function	251-255	98.4-100%				



## 14. Guide to patterns

The following tables show the pixel patterns (when using suitable DMX mode).

### Static patterns

Value	Pattern	Value	Pattern
000 – 005		036	
006		037	
007		038	
008		039	
009		040	
010		041	
011		042	
012		043	
013		044	
014		045	
015		046	
016		046	
017		048	
018		049	
019		050	
020		051	
021		052	
022		053	
023		054	
024		055	
025		056	
026		057	
027		058	
028		059	
029		060	
030		061	
031		062	
032		063	
033		064	
034		065	
035			

**Static patterns(continued)**

Value	Pattern
066	
067	
068	
069	
070	
071	
072	
073	
074	
075	
076	
077	
078-079	

## Animated patterns

All animated patterns are available in four configurations using the 4 DMX values given for each pattern.

Value 1=Standard

Value 2=Reversed

Value 3=Inverted

Value 4=Inverted + Reversed

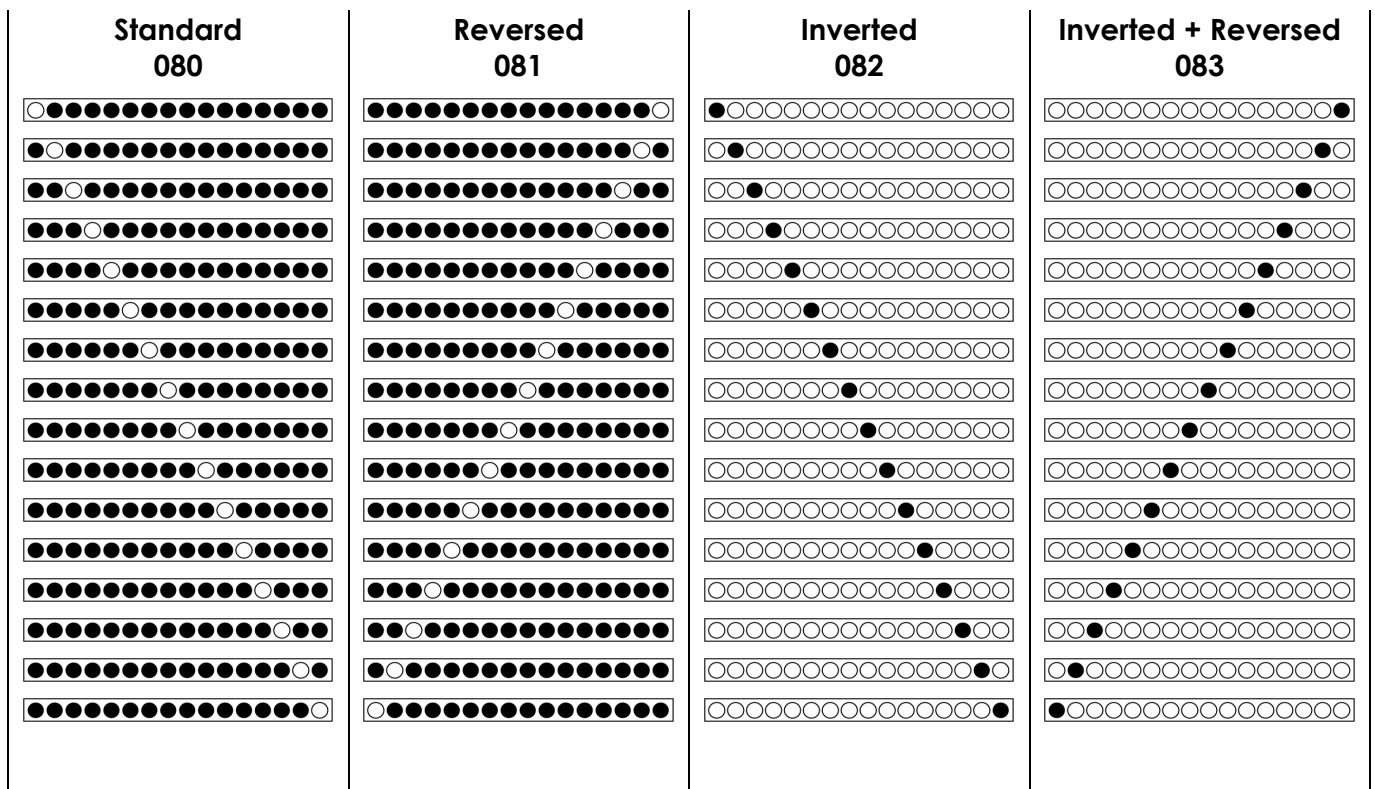

For Random Pixel patterns, the two values give Normal and Inverted versions of the pattern.



Value                    Pattern

080	
081	
082	
083	

#

084	
085	
086	
087	

#

088	
089	
090	
091	

Value                    Pattern

092	
093	
094	
095	

096	
0970	
98	
099	

100	
101	
102	
103	

104	
105	
106	
107	

108	
109	
110	
111	

112	
113	
114	
115	

Value                    Pattern

116	
117	
118	
119	

120	
121	
122	
123	

124	
125	
126	
127	

128	
129	
130	
131	

Value	Pattern
132	
133	
134	
135	
136	
137	
138	
139	

Value	Pattern
140	
141	
142	
143	

144	
145	
146	
147	

148	
149	
150	
151	

152	
153	
154	
155	

156	
158	
158	
159	

160	
161	Random 1 Pixel
162	
163	Random 2 Pixel
164	
165	Random 3 Pixel

Value	Pattern
166	
167	Random 4 Pixel
168	
169	Random 5 Pixel
170	
171	Random 6 Pixel
172	
173	Random 7 Pixel
174	
175	Random 8 Pixel
176	
177	Random 9 Pixel
178	
179	Random 10 Pixel
180-255	Reserved



## 15. Technical specifications

### Optics

Light source: 16 x 20 W RGBW LEDs  
Lifetime: 20 000 hrs. approx. to > 70% luminous output  
ConsistentColor™ optics  
Beam angle (half peak): 8° - 40°

### Effects

All 16 LEDs controllable individually (depending on DMX mode)  
Color mixing: RGBW, continuously variable, 8 and 16-bit  
Color temperature correction: CTO, electronic, fine-tuning via RGBW  
Motorized zoom: 8° - 40°  
Shutter/strobe: Variable strobe up to 20 Hz  
Strobe control: Adjustable flash intensity, rate (max. 16.67 Hz) and duration,  
Dimmer: SteadyColor™ hi-res dimming, 0-100% continuous, choice of dimming curves  
Virtual color wheel: 39 colors incl. whites (2700, 3200, 4200, 5600, 7200 and 8000 K)  
FX engine with static and animated patterns, variable speed and fade options  
Random strobe with variable speed up to 20 Hz and pulse effects

### Control

Control systems: DMX, RDM  
DMX channel footprint: 13 / 43 / 79 / 6 depending on mode  
Pixel mapping options: Whole fixture as one pixel, 16 individual pixels  
Setting and addressing: Onboard control panel with LCD display, RDM  
Wireless DMX: Optional accessory  
DMX compliance: USITT DMX512  
RDM compliance: ANSI/ESTA E1.20

### Installation

Options: Standing on horizontal surface, mounted on rigging truss or pipe at any angle  
Operating position: Any  
Minimum distance to combustible materials: 0.2 m (8 in.)  
Minimum distance to illuminated surfaces: 0.2 m (8 in.)  
Installation environment: Temporary or permanent indoor installation, temporary outdoor installation  
Secondary attachment: Two eyelets for safety cable attachment

### Electrical

AC mains power: 100-240 V nominal, 50/60 Hz  
Power supply unit: Auto-ranging electronic switch mode  
Maximum power consumption, all LEDs at 100% output: 330 W

#### **Maximum permitted number of fixtures daisy-chained to power**

3 x FS16Z total @ 100-120 V, 60 Hz  
6 x FS16Z total @ 200-240 V, 50 Hz

## **Connections**

AC mains power in and thru (out): Neutrik powerCON TRUE1 with sealing cap  
Control data in and thru (out): Neutrik etherCON with sealing cap

## **Construction**

Ingress protection rating: IP65  
Fixture housing: Extruded aluminum  
Color: Black

## **Thermal**

Cooling: Convection  
Minimum ambient temperature: -10° C (14° F)  
Maximum ambient temperature: 40° C (104° F)  
Max. total heat dissipation (calculated): 1130 BTU/hr.

## **Included items**

Power cable with Neutrik powerCON TRUE1 mains input plug  
2 x Adjustable Tilt Brackets  
Glare shield  
2 x Quick-release Locking Pins

## **Dimensions and weight**

Height including bracket: 231 mm / 9.09 ins.  
Height without bracket: 181 mm / 7.12 ins.  
Width: 90 mm / 3.54 ins.  
Depth: 1020 mm / 40.28 ins.)  
Weight: 13 kg (28.7 lbs.)



## 16. Dimensions

### *FS16Z with folding brackets*

All dimensions are in millimeters

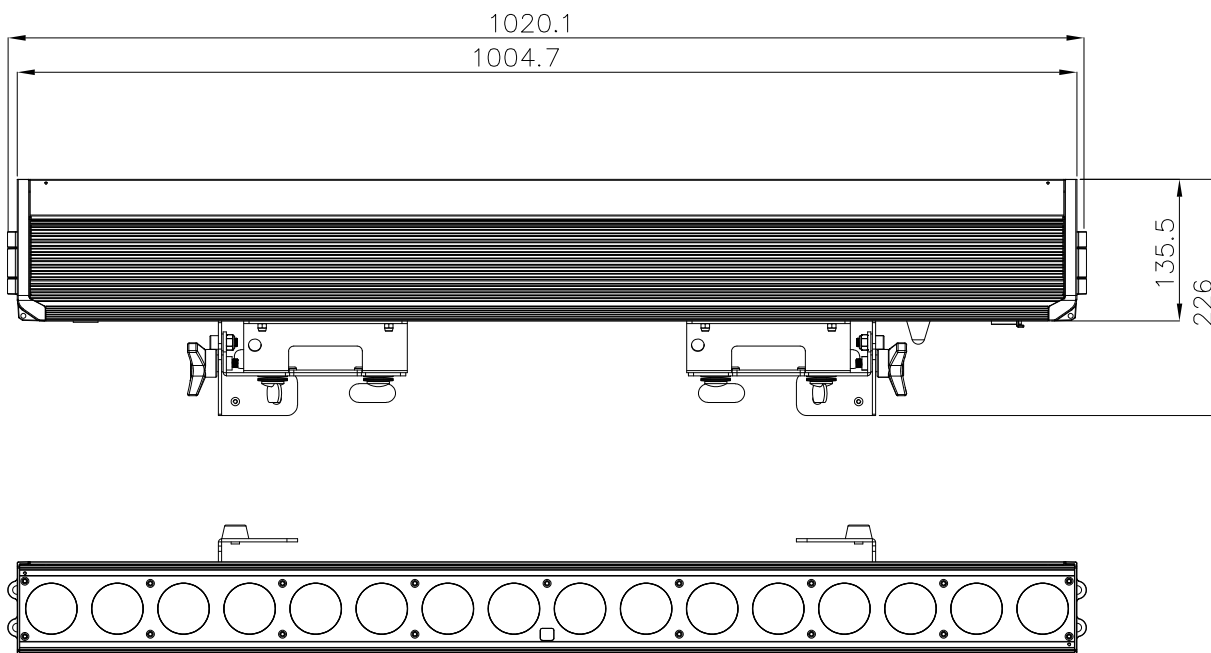

### *Folding brackets*

